



Demystifying Radio Frequency Fields and Radio Frequency Components

Tom Mullineaux



The Situation by the end of the 18th Century



ELECTRICITY



Two types of electricity known

Static and Flowing

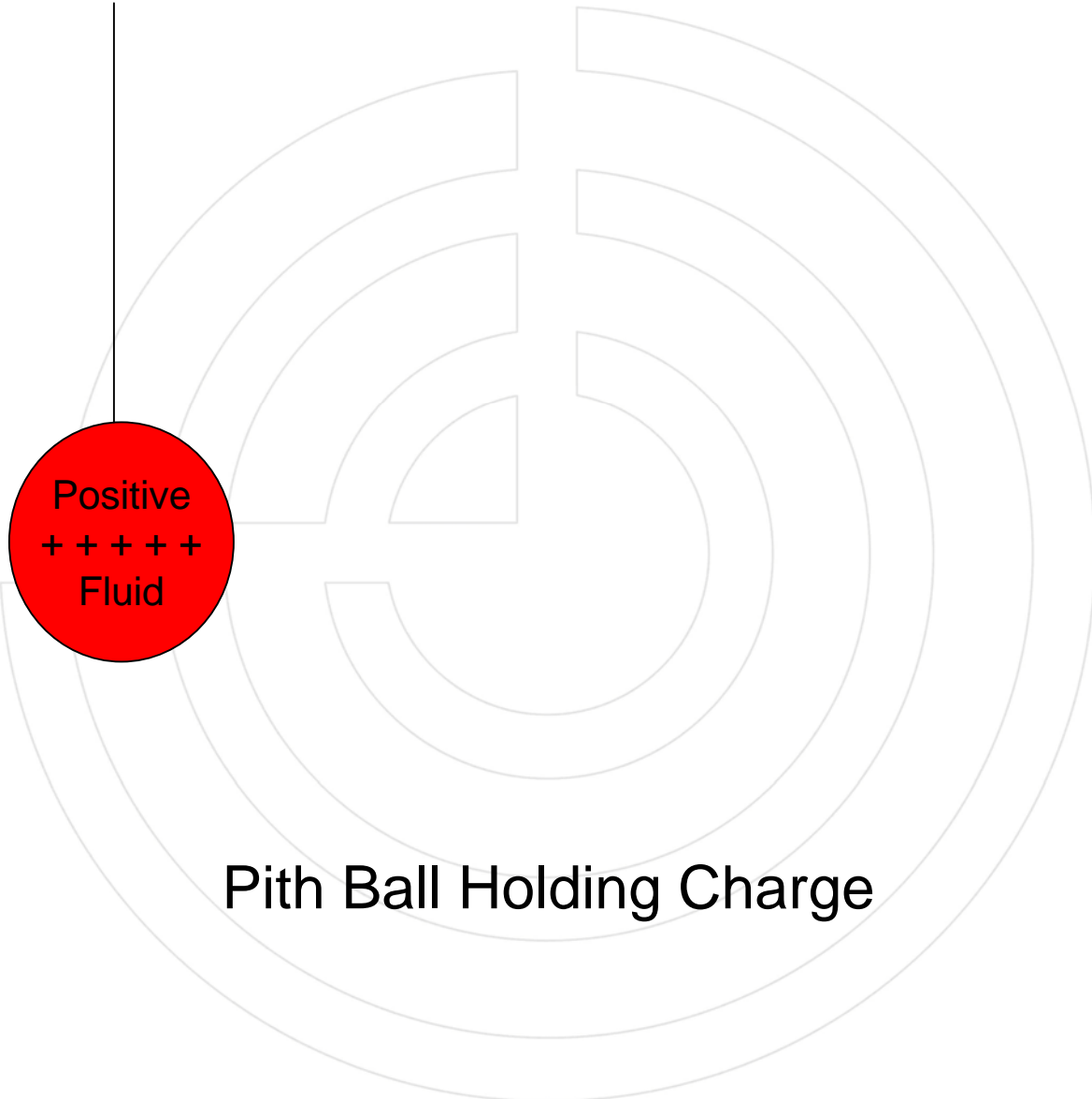

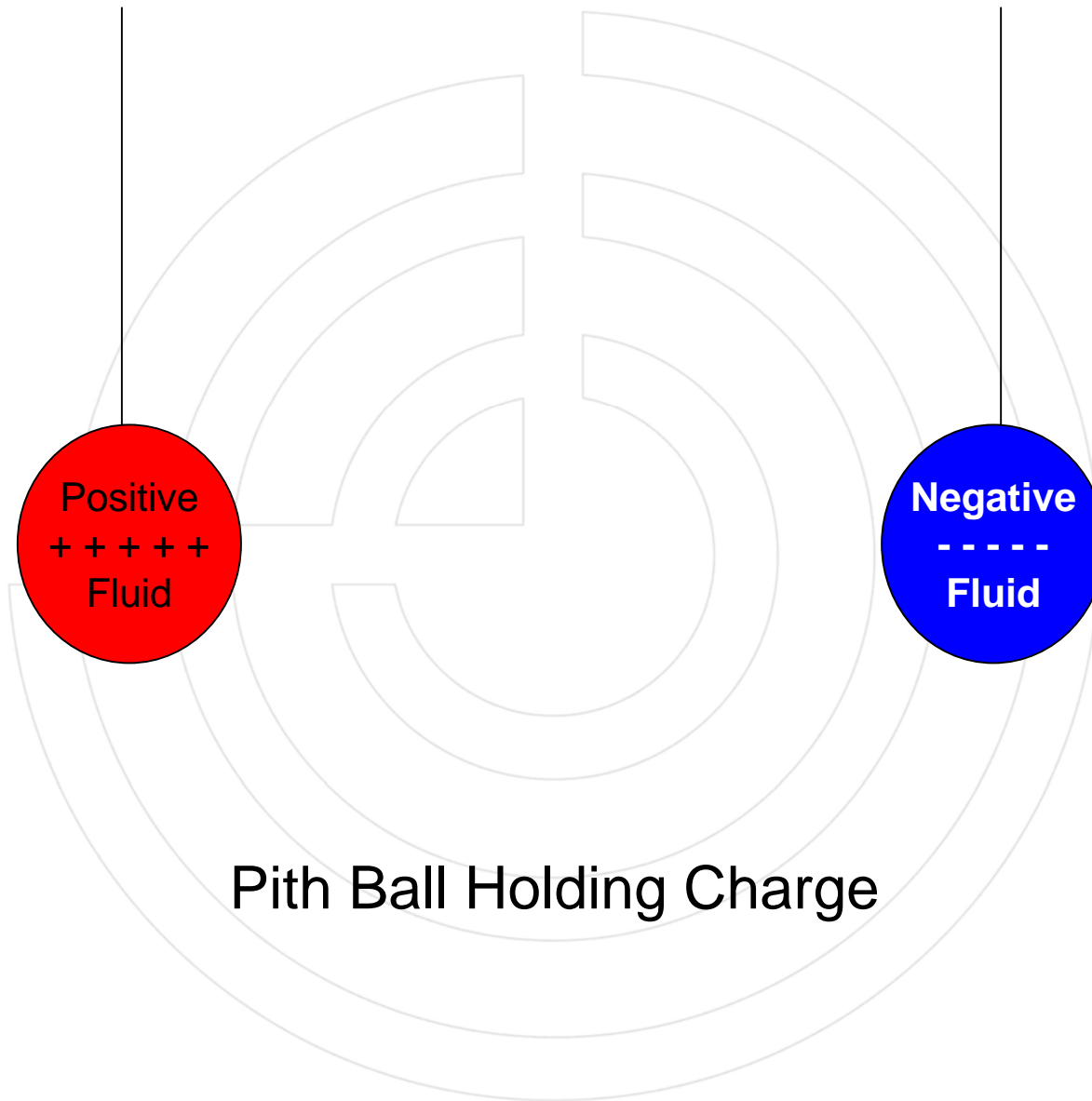

Pith Ball Holding Charge

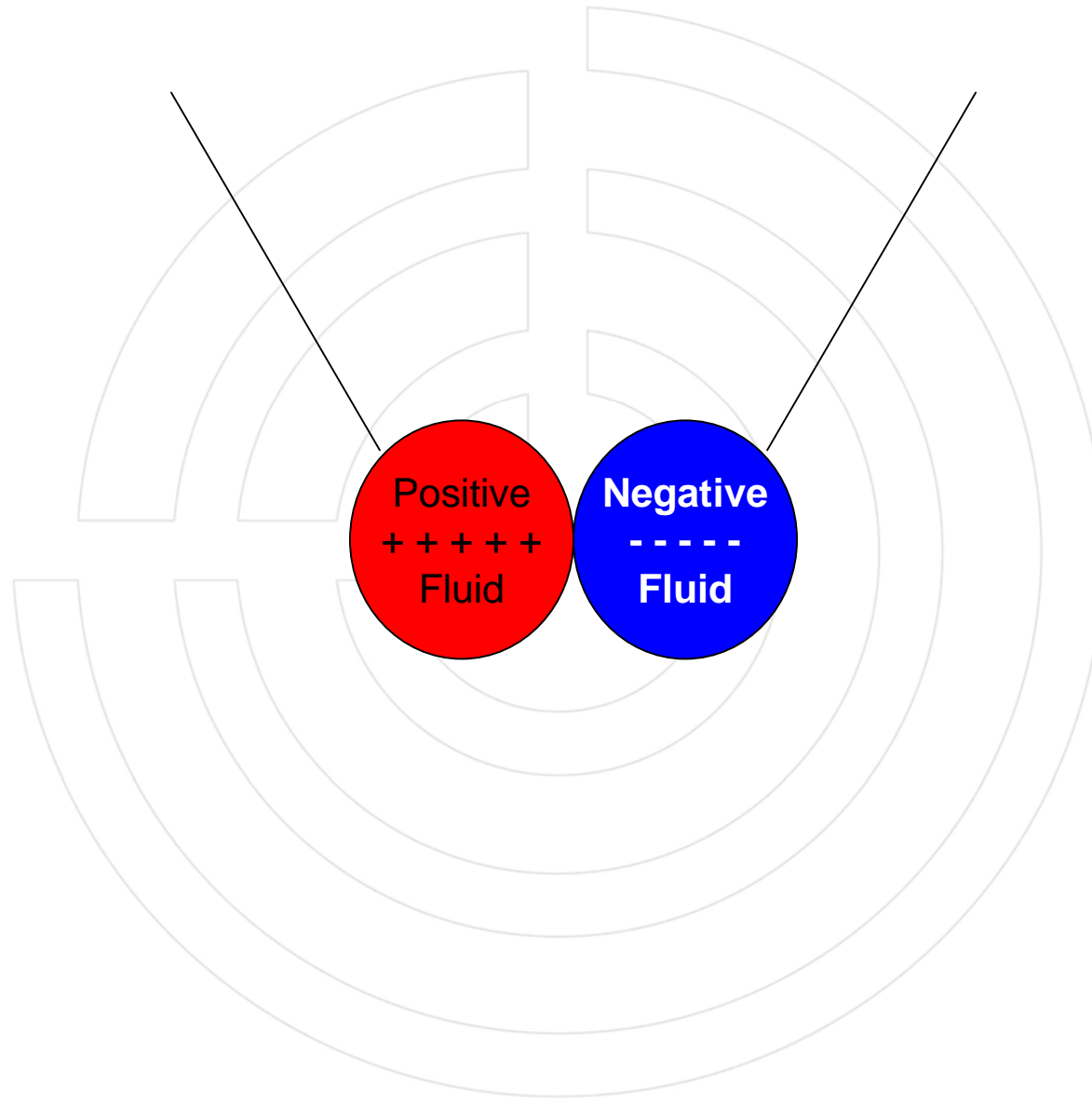

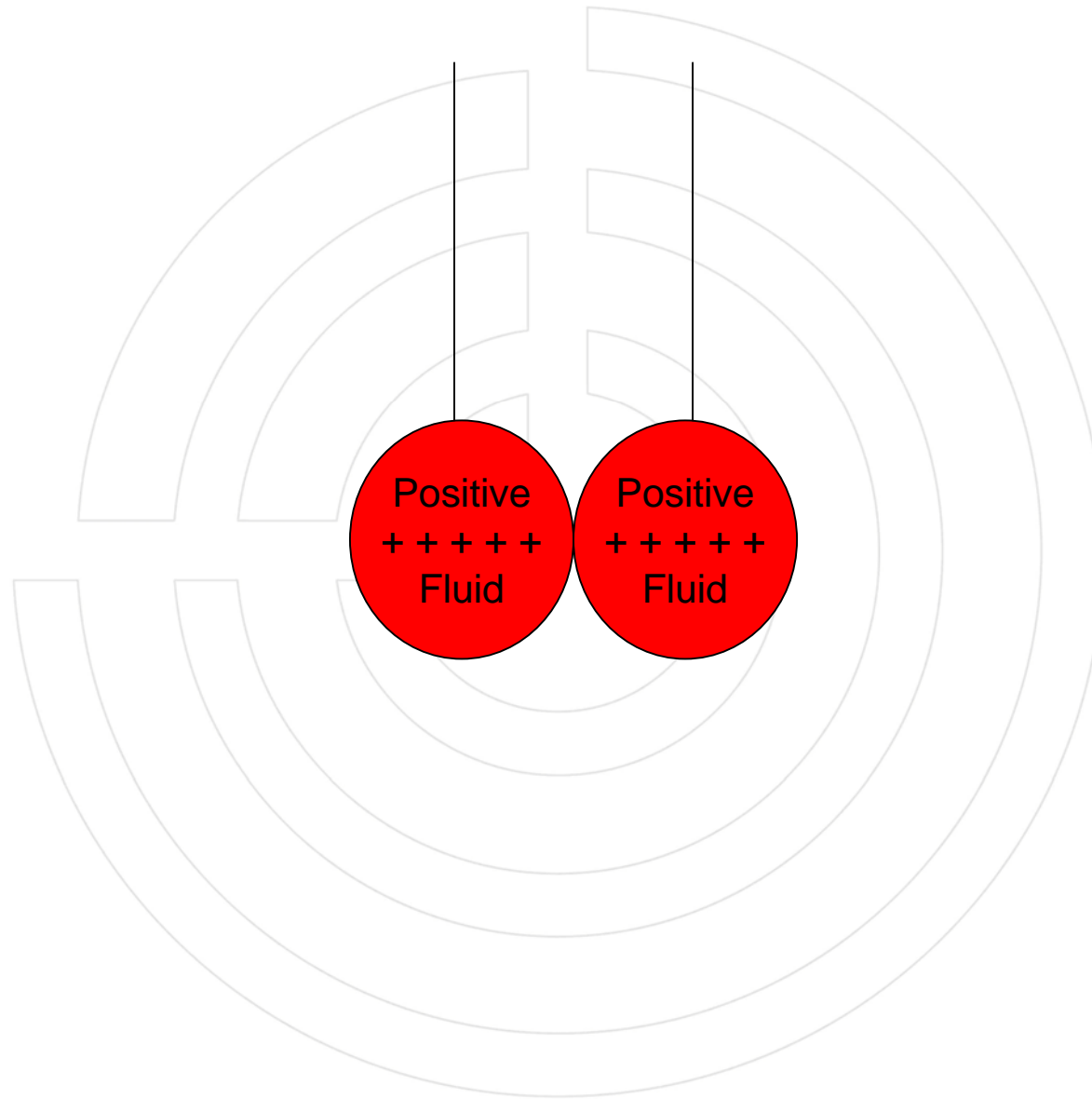

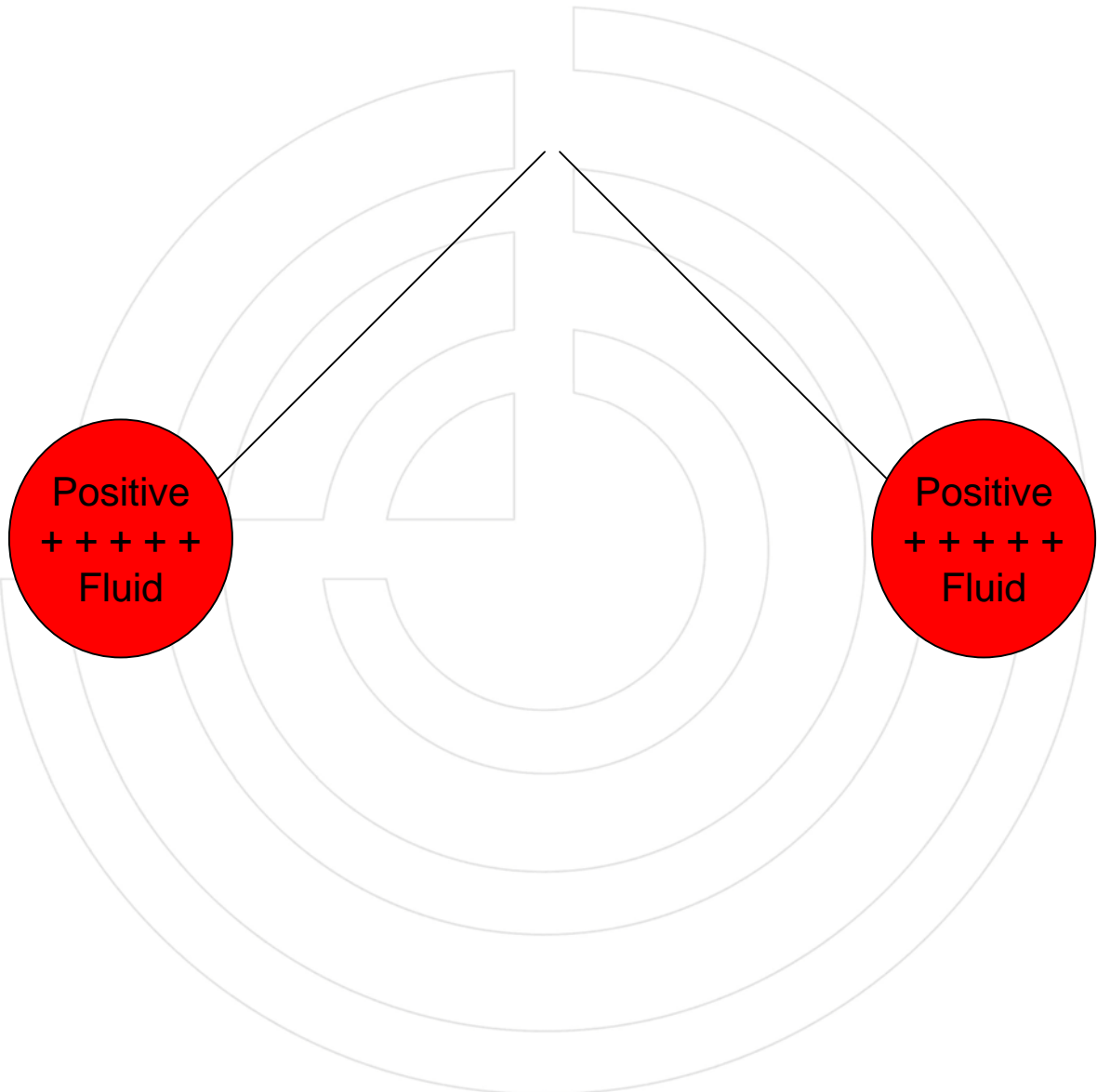

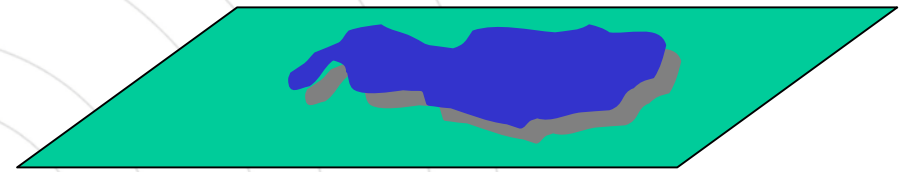
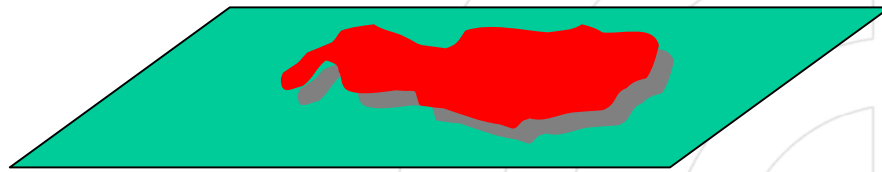

- Charge regarded as fluids
- Two fluid theory
- Positive charge fluid 'vitreous'
- Negative charge fluid 'resinous'

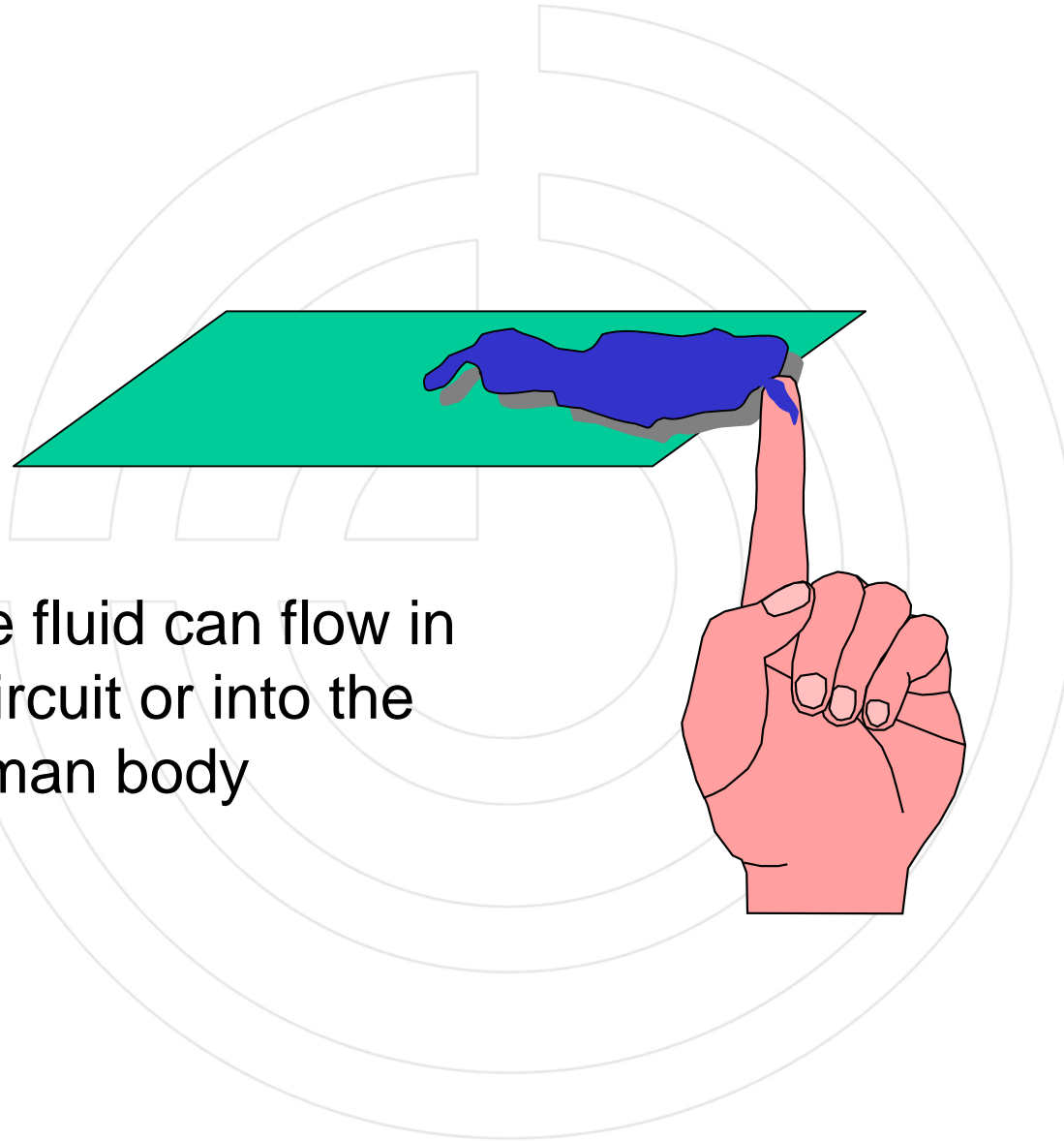

The fluid can flow in
a circuit or into the
human body

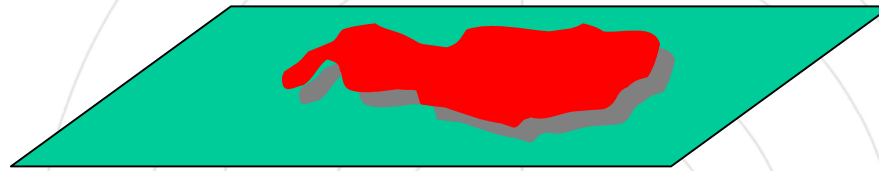

Benjamin Franklin
posited that charge was
a single invisible fluid
present in all bodies
and gave the terms
'negatively charged'
and 'positively charged'

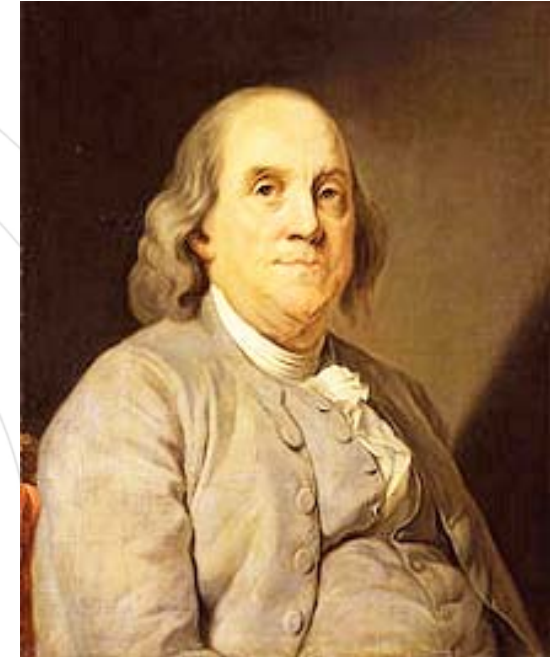

1706-1790



2nd type of electricity known

Flowing

Voltaic
Pile

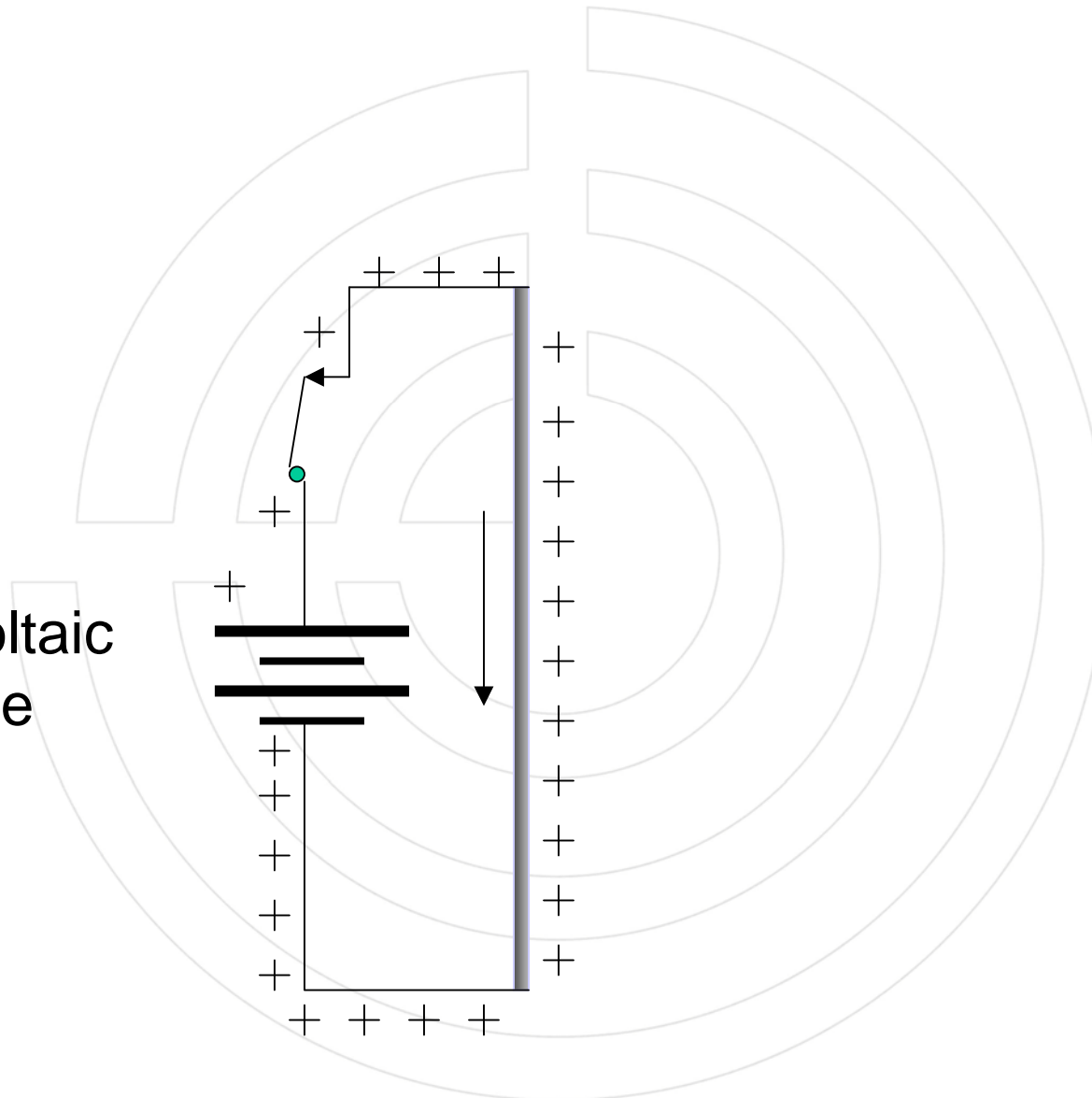

What were capacitors once called?

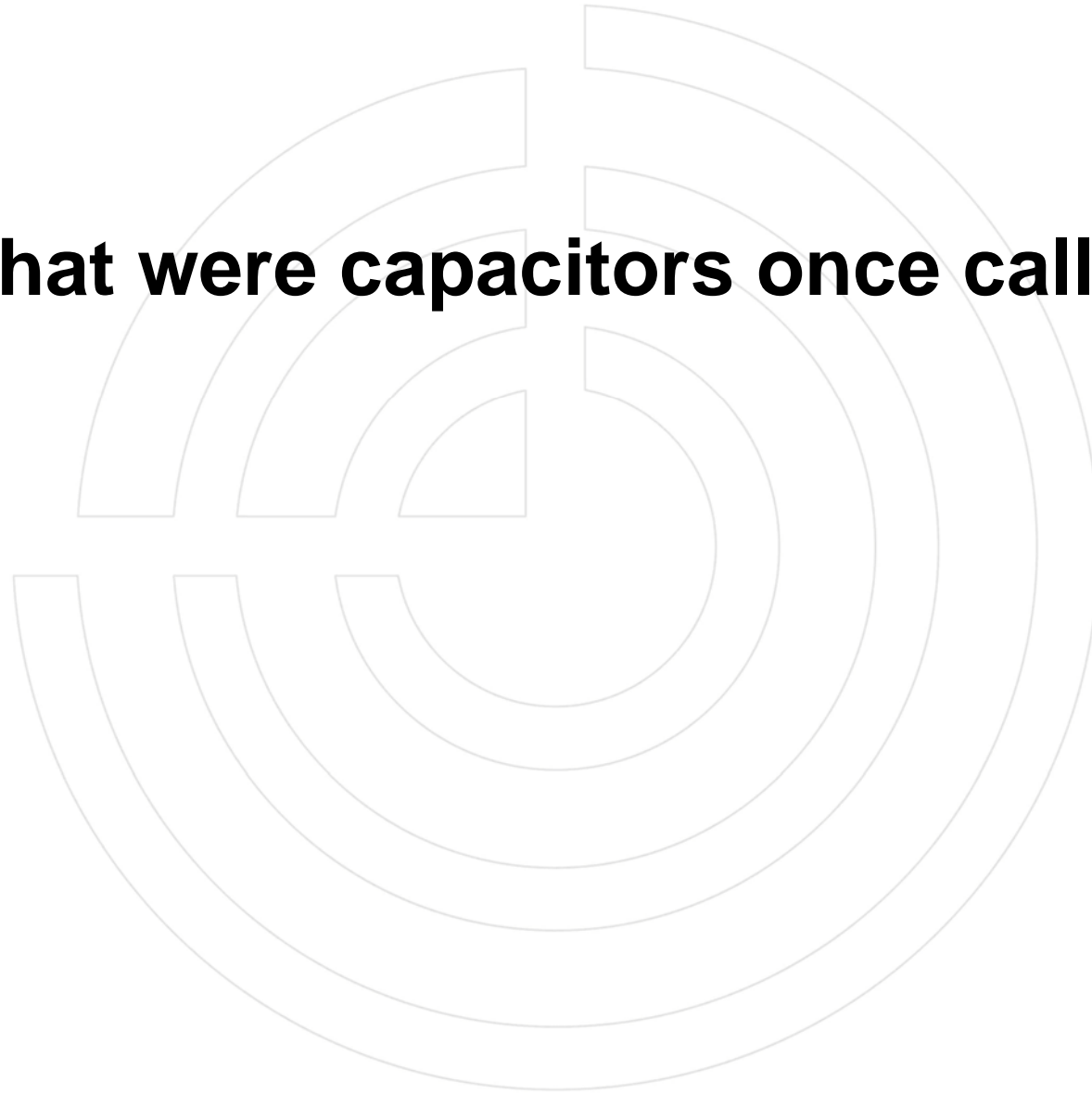

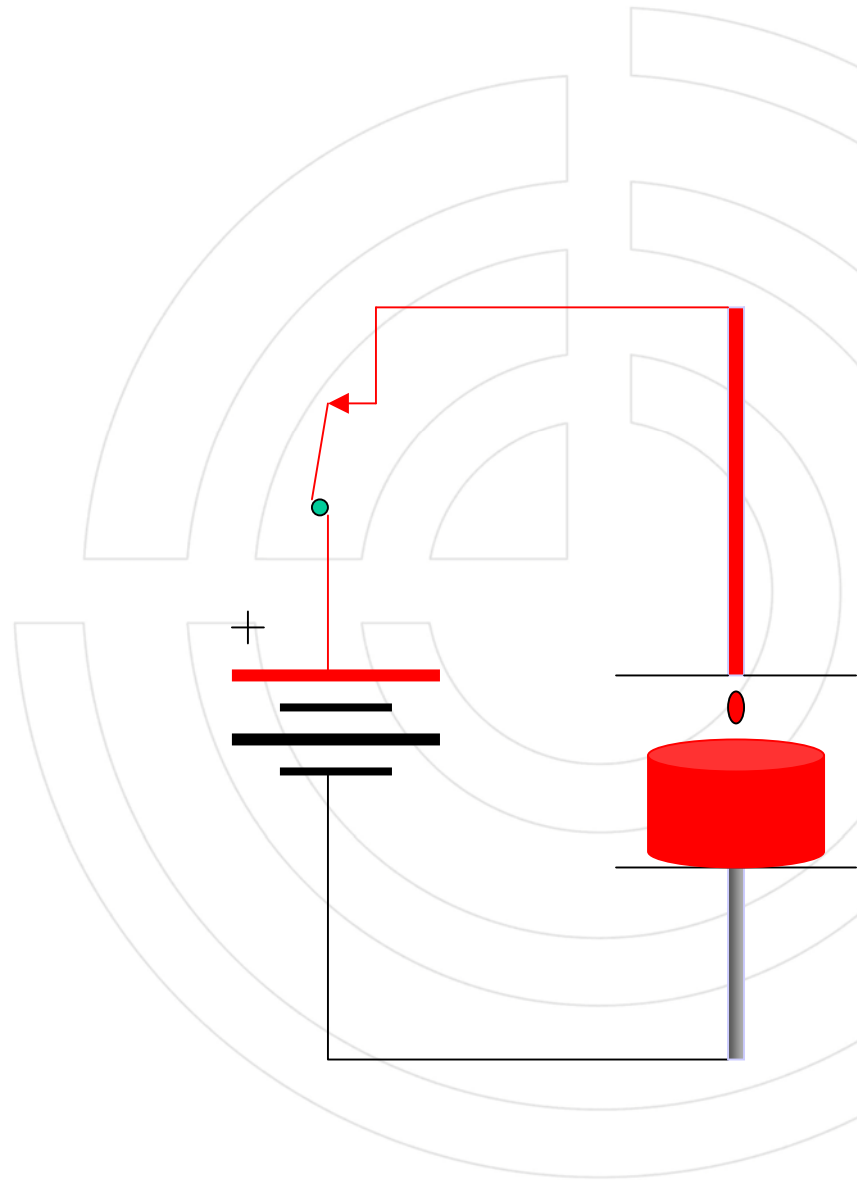

Capacitors were once known as condensers because it was thought they 'condensed' the fluid

Only one Type of Magnetism Known

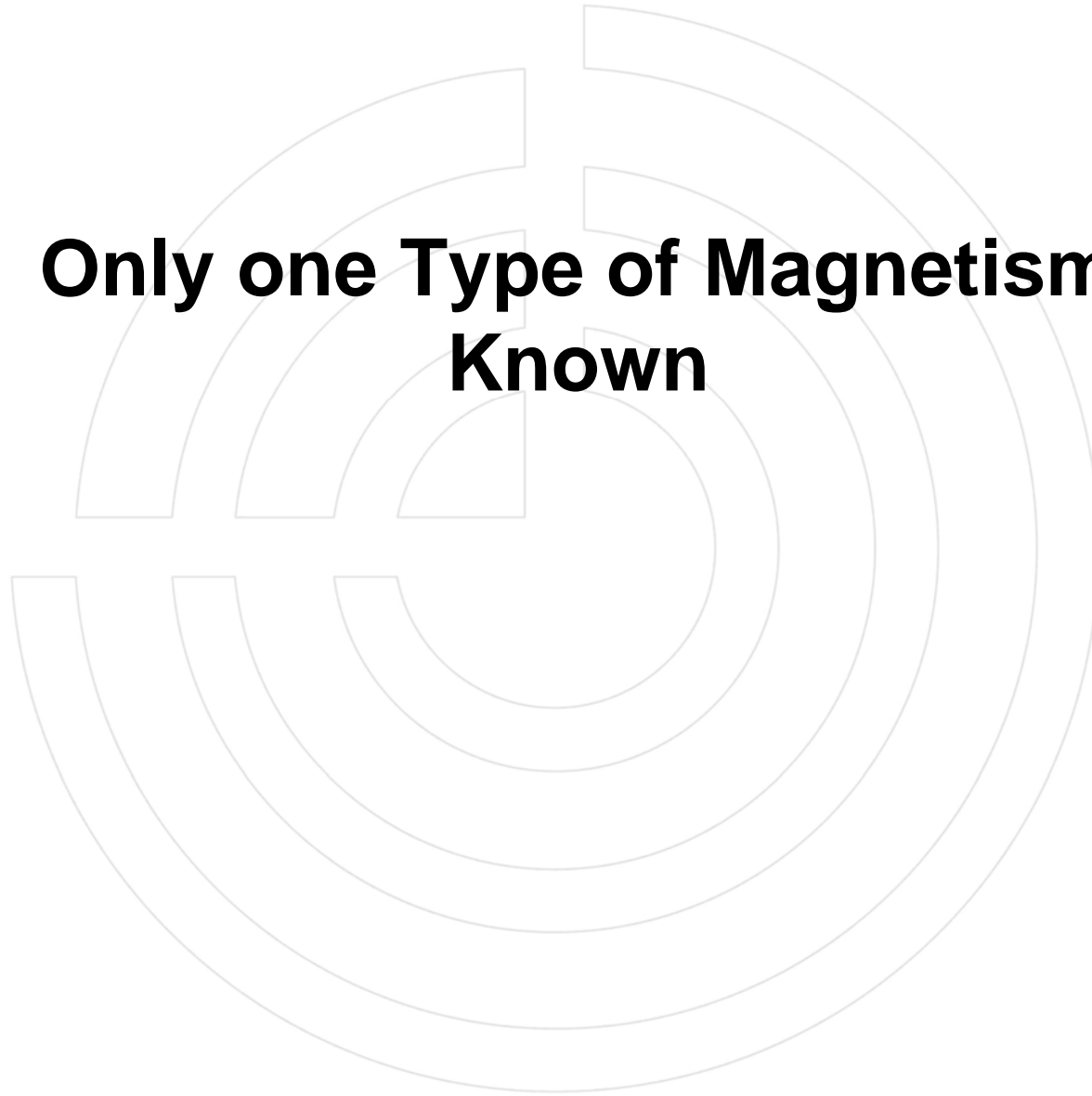

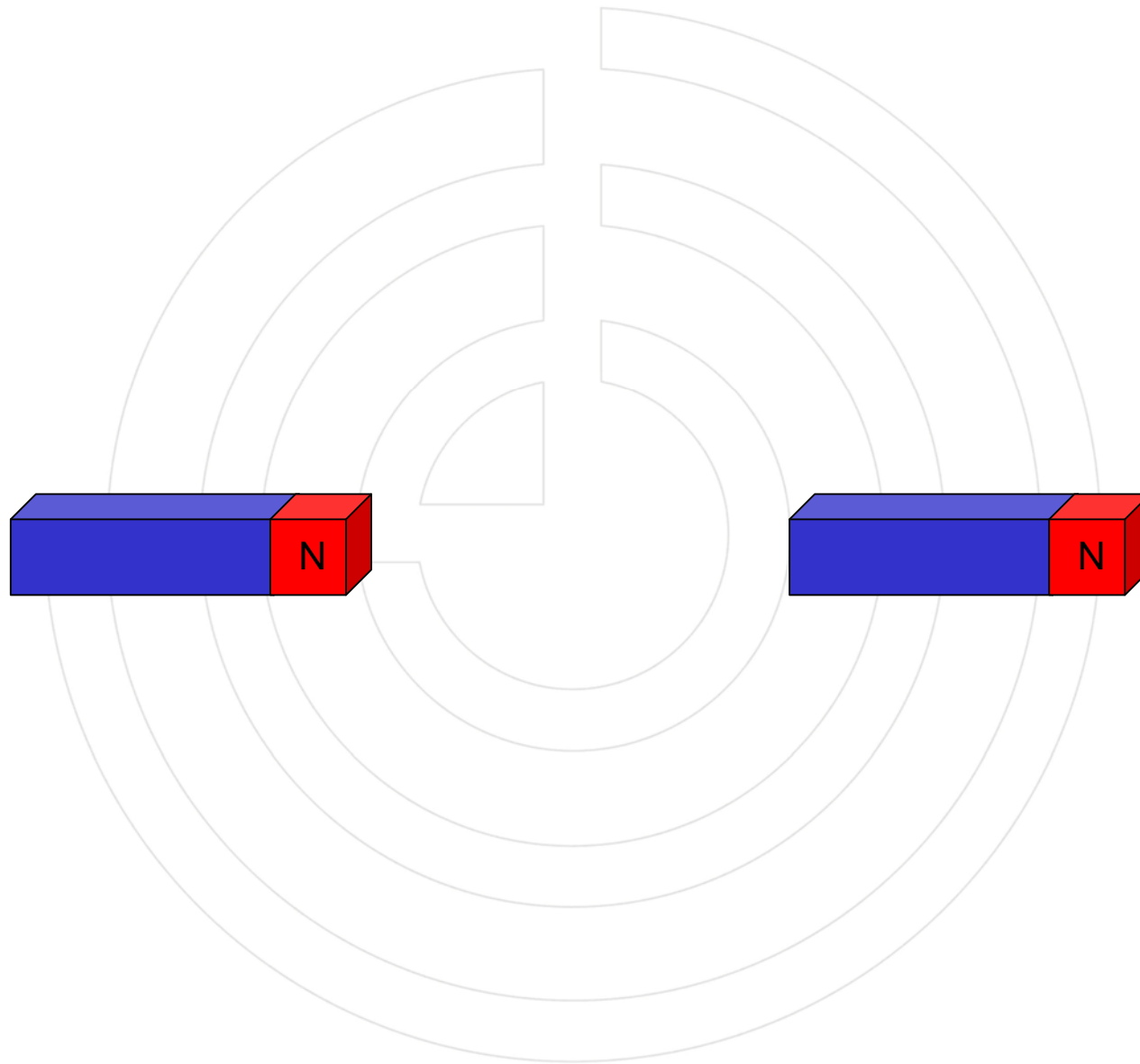

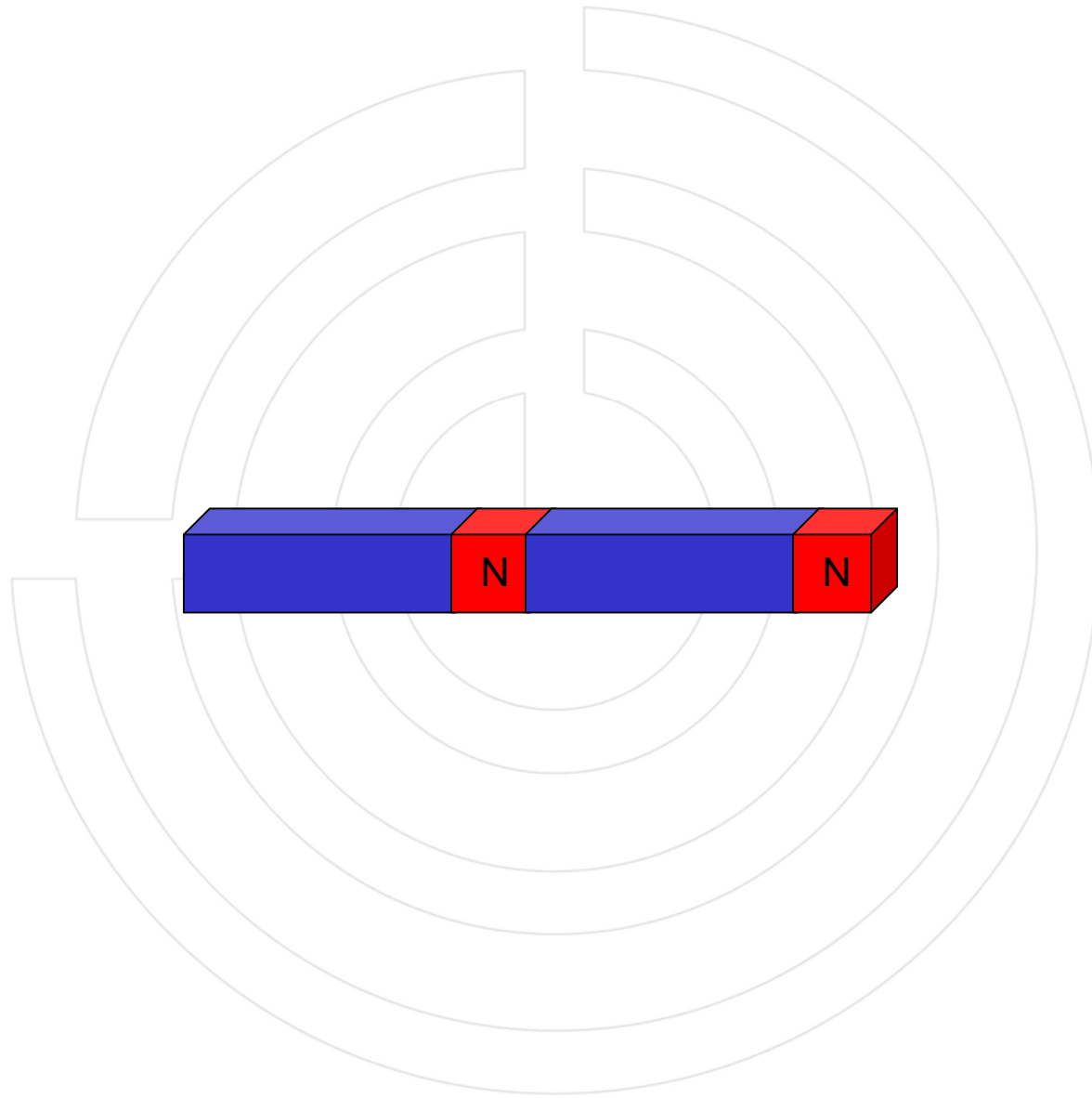

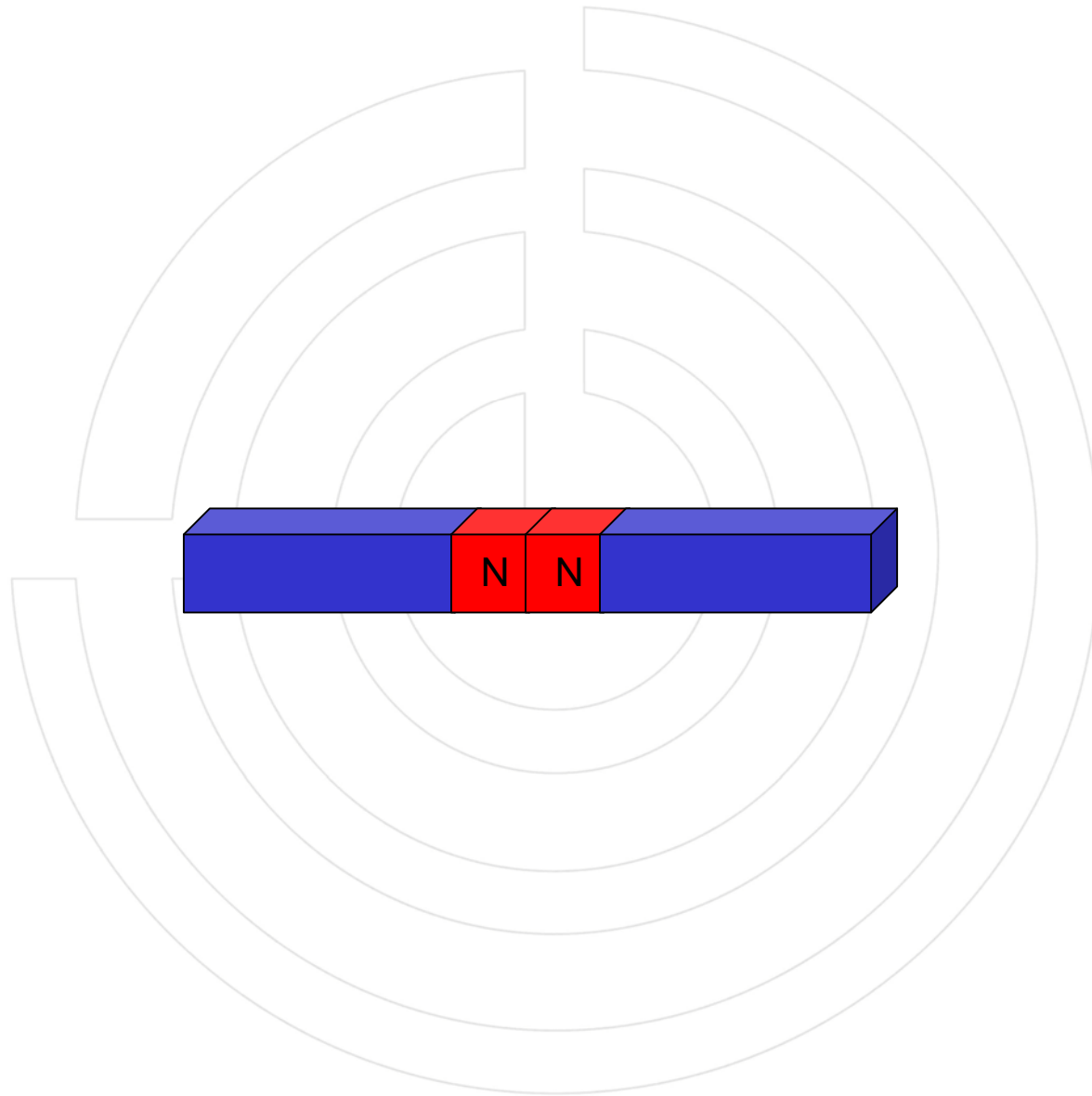

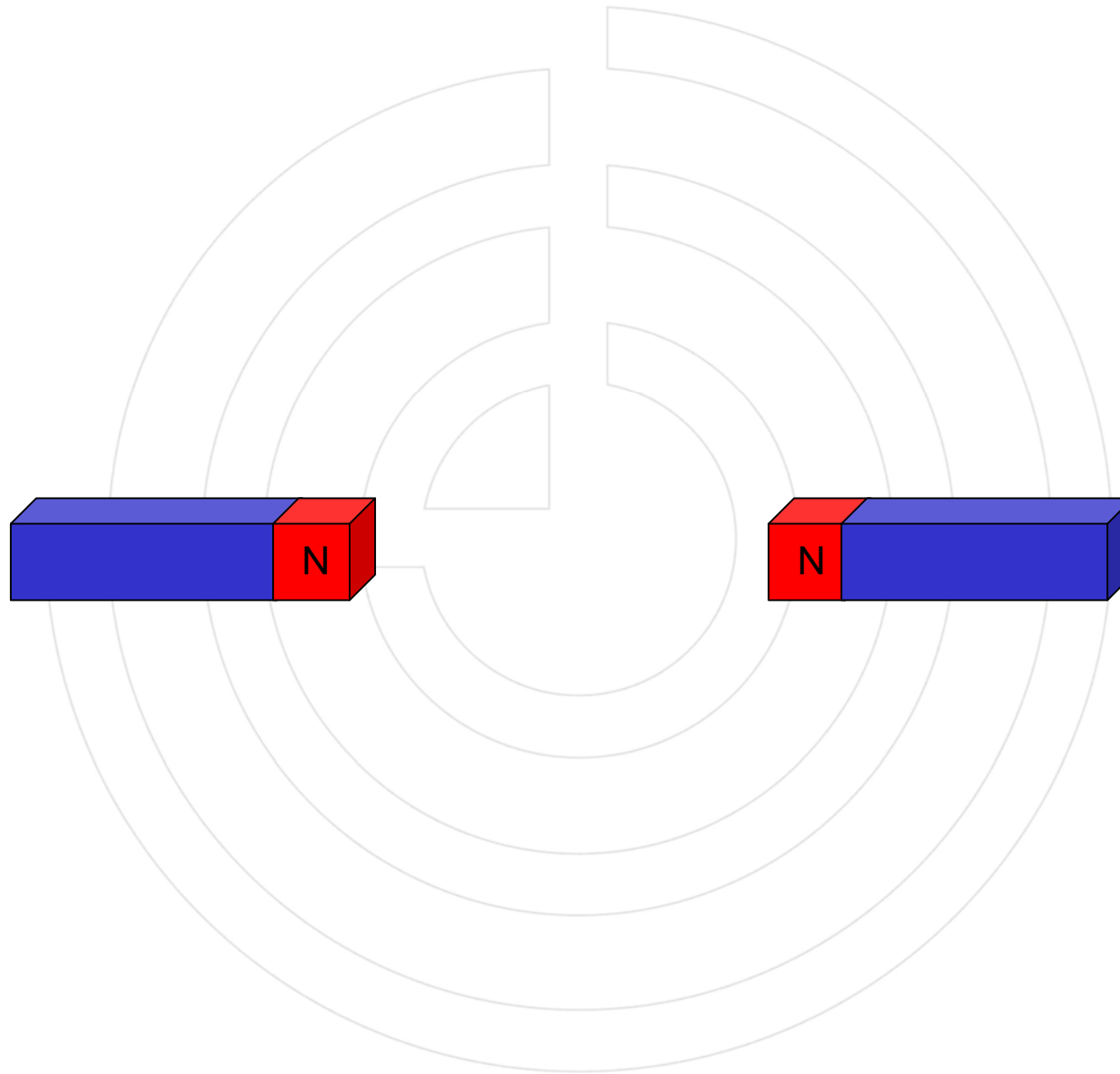

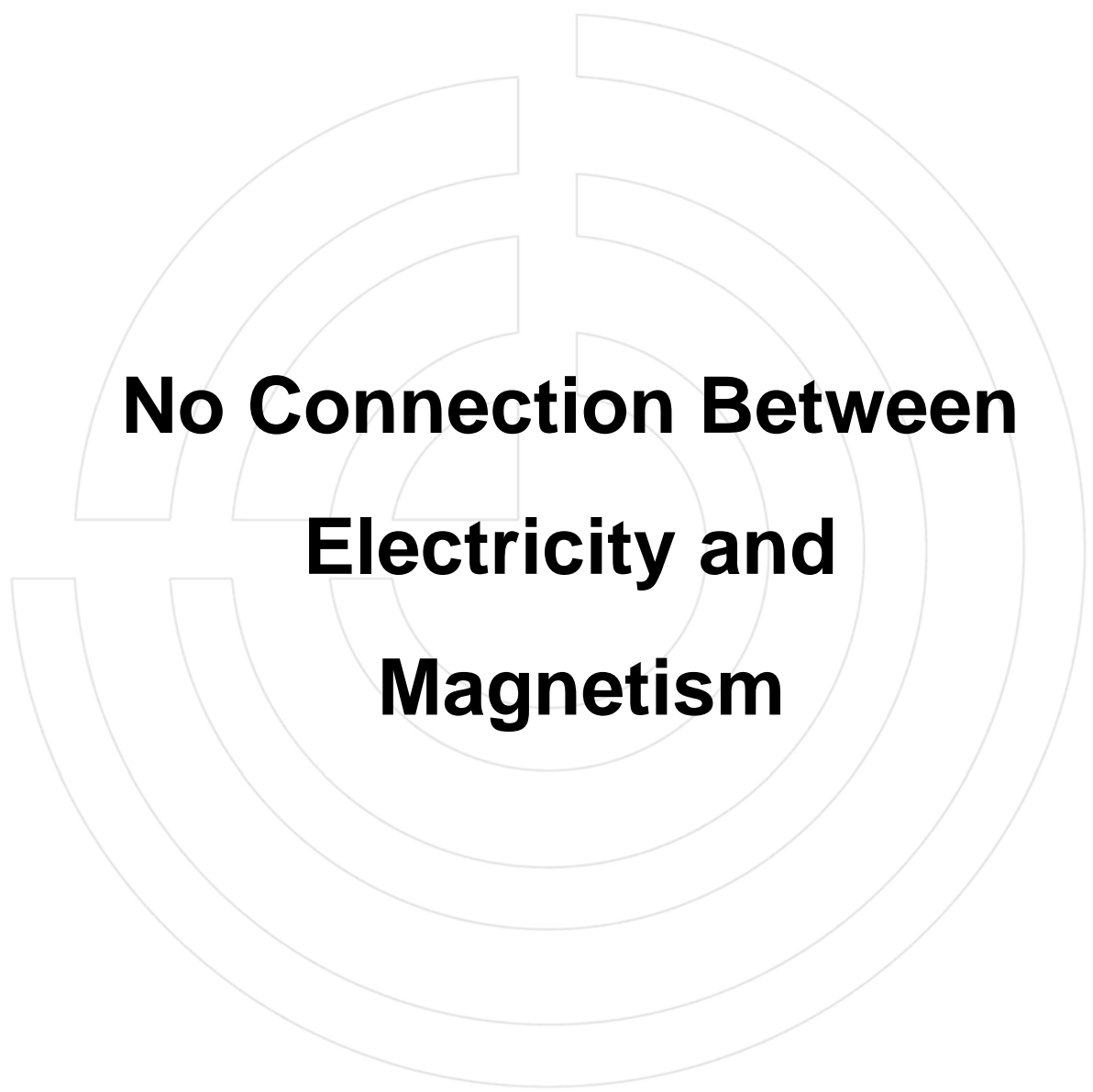

**No Connection Between
Electricity and
Magnetism**

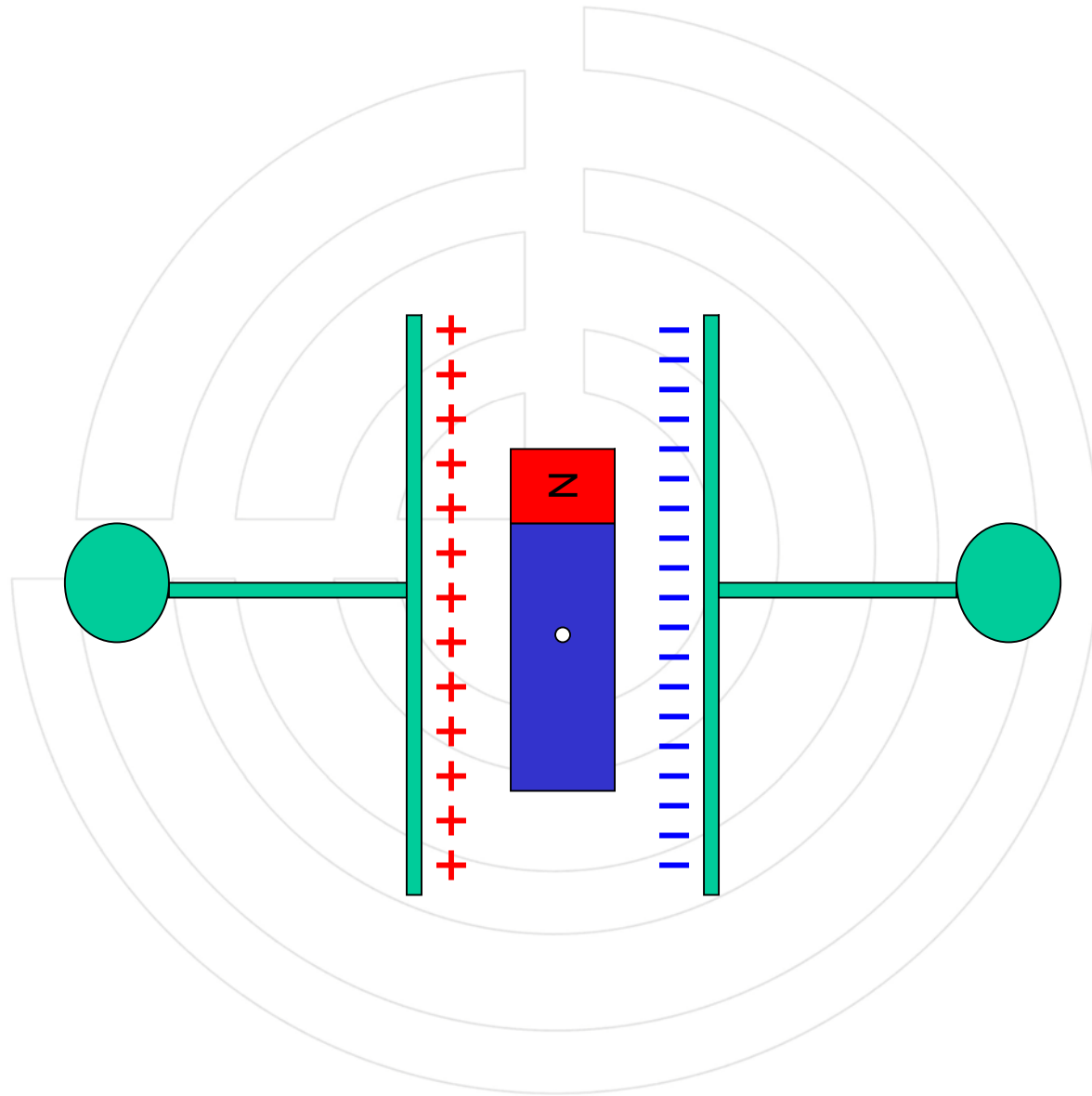

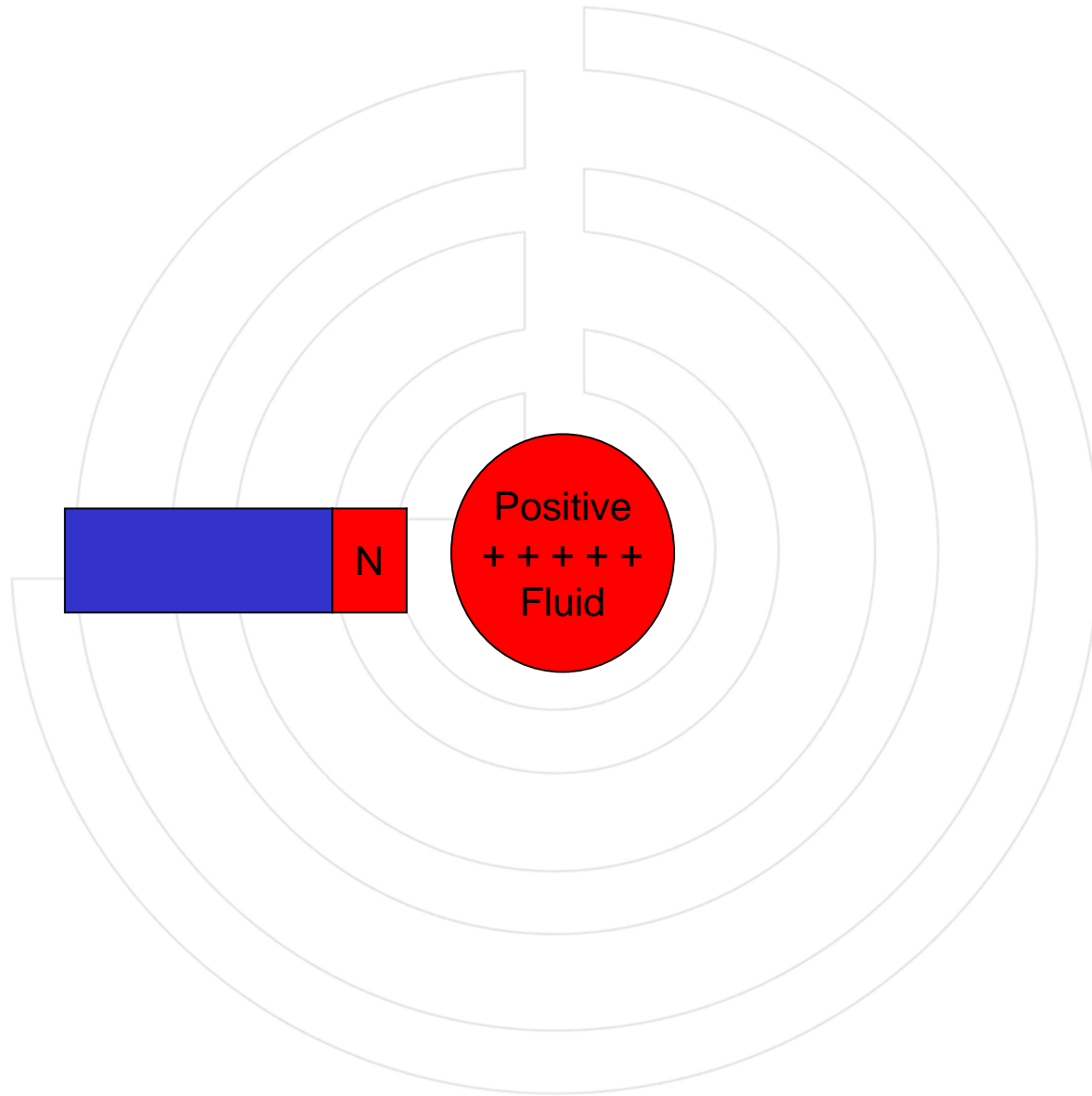

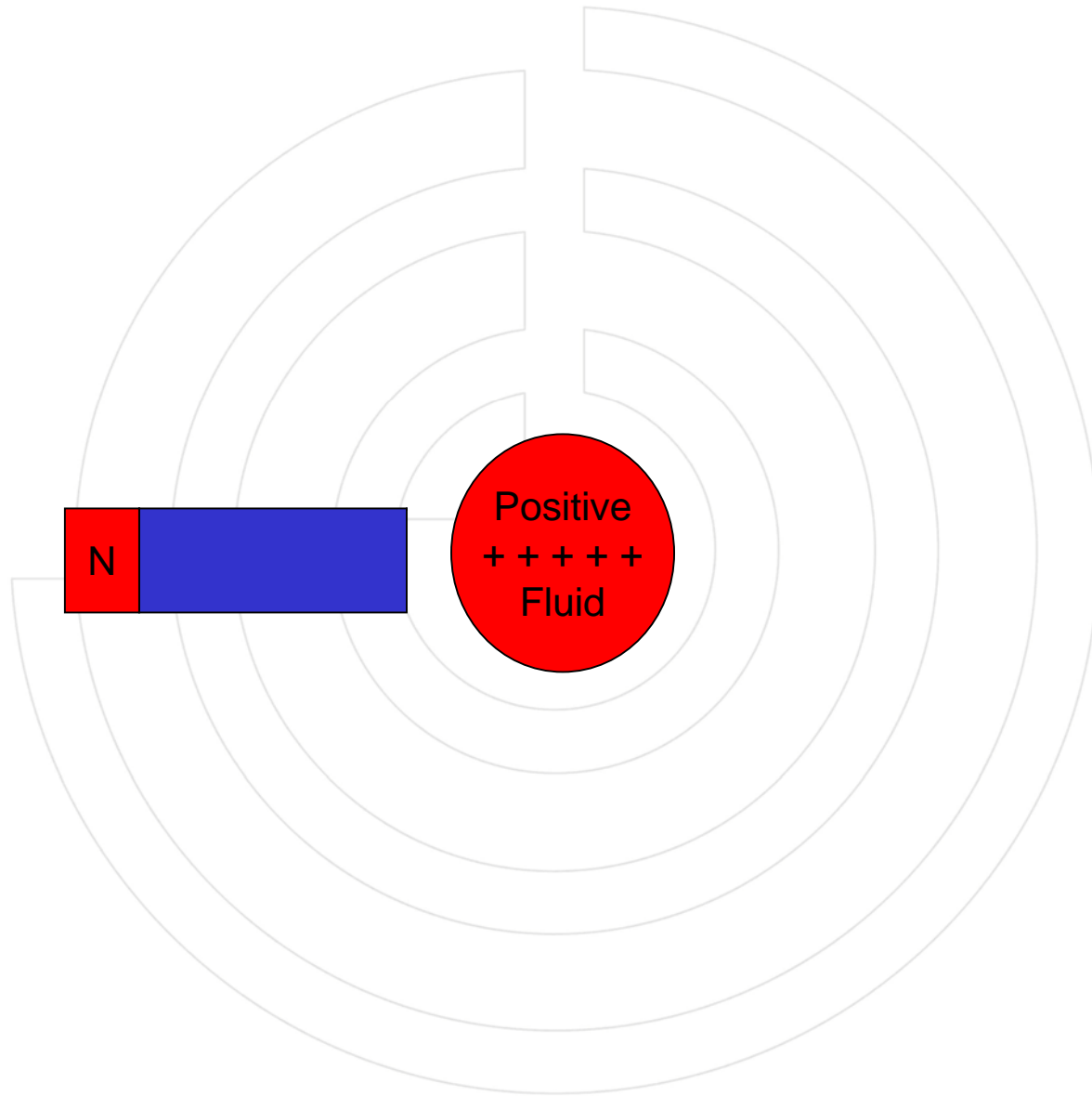



UNTIL..... IN 1820.....



Hans Christian Ørsted
(1777-1851)





Hans Christian Ørsted
(1777-1851)

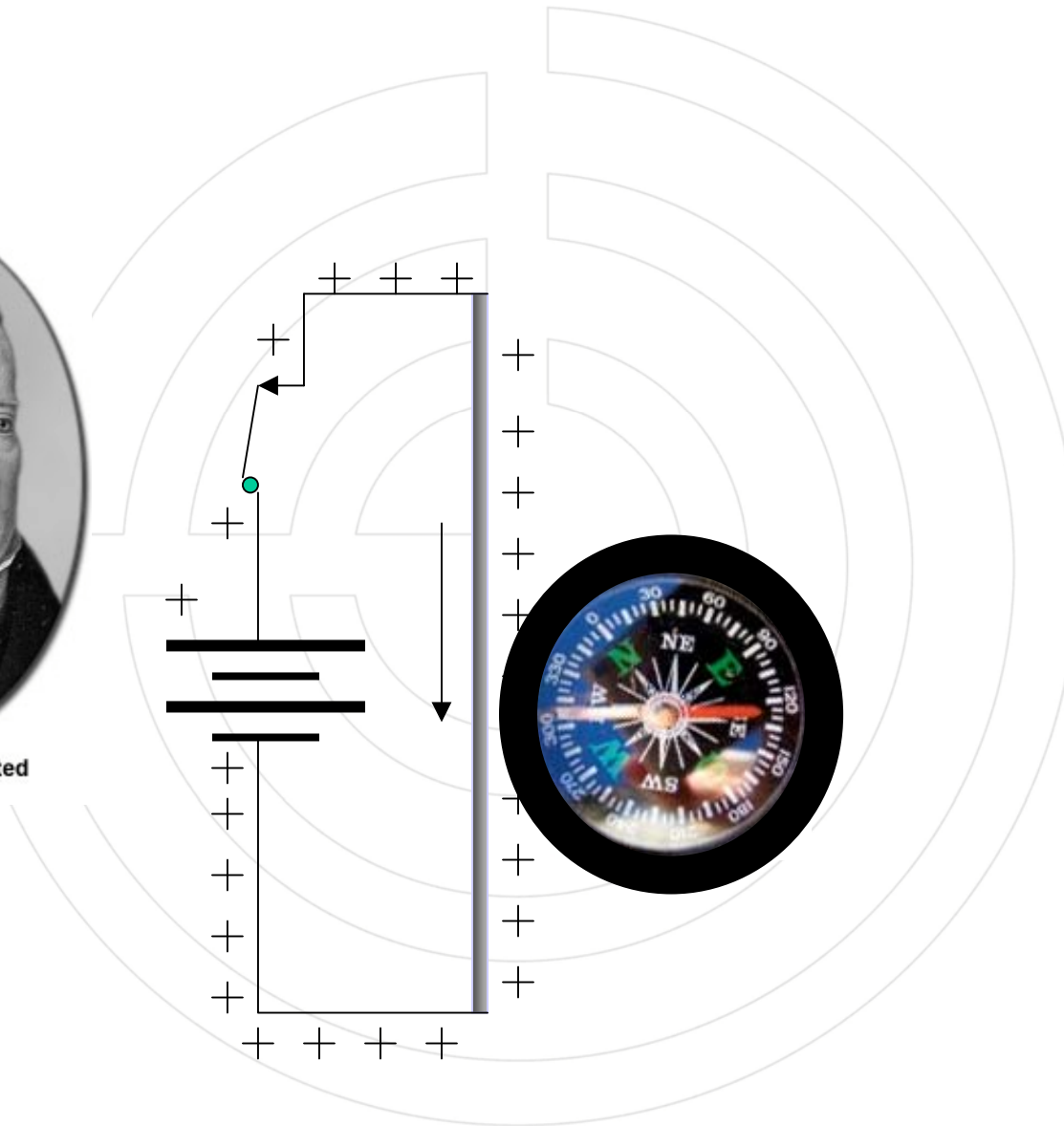

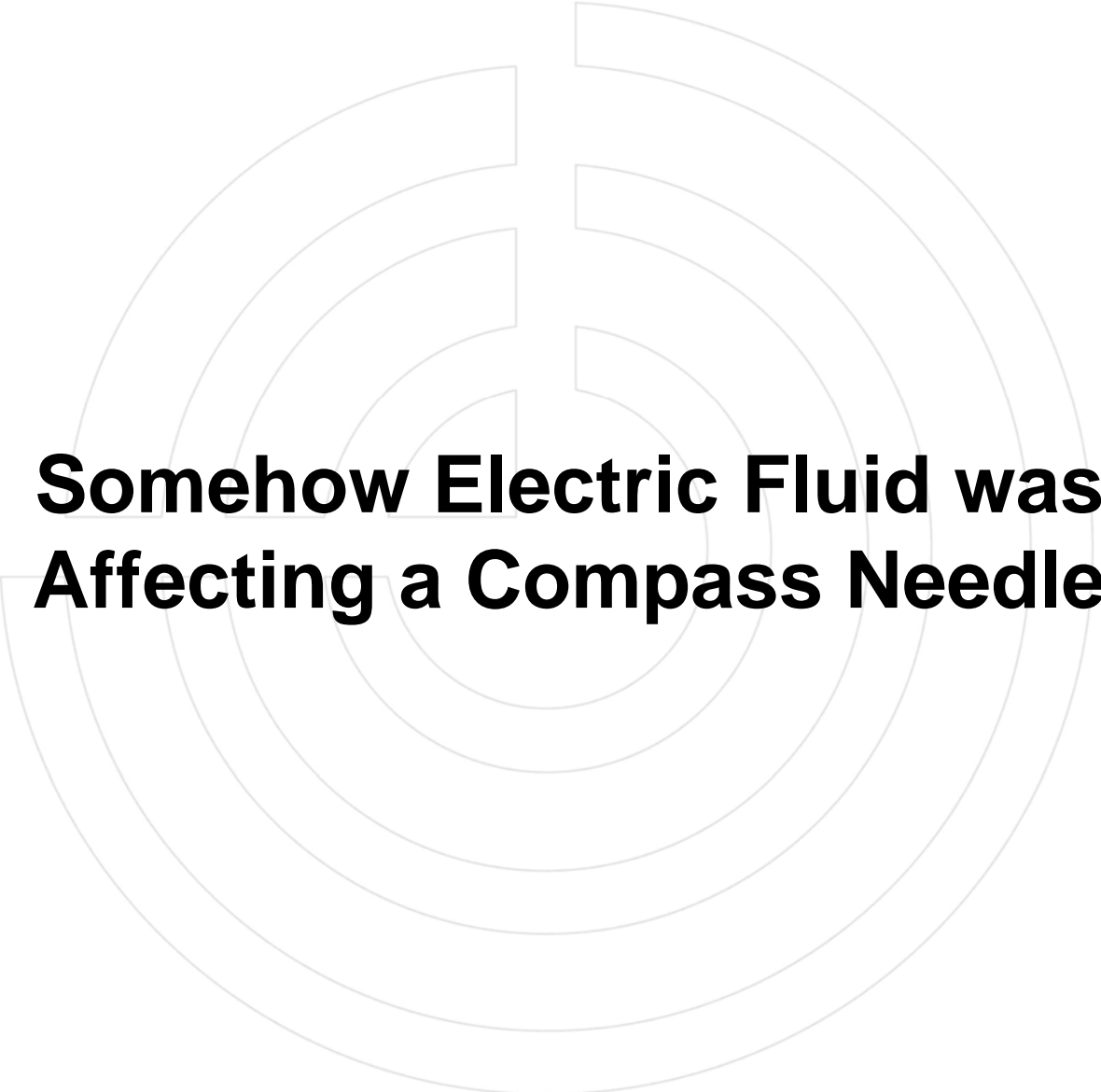

Somehow Electric Fluid was Affecting a Compass Needle

**Intense Interest in Scientific
Community**

**Let the Great Race
Begin!**



Alessandro Volta
(1745-1827)



Michael Faraday (1791-1867)



André-Marie Ampère
(1775-1836)



Georg Ohm
(1789-1854)



Carl Friedrich Gauss
(1777-1853)



Humphry Davy
(1778-1829)



Alessandro Volta
(1745-1827)

Georg Ohm
(1789-1854)



Faraday (1791-1867)



Carl Friedrich Gauss
(1777-1853)



André-Marie Ampère
(1775-1836)



Humphry Davy
(1778-1829)



**Georg Ohm
(1789-1854)**

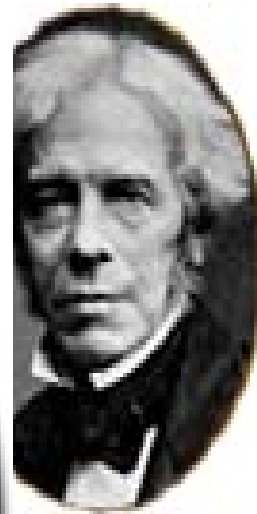

Michael Faraday (1791-1867)



**André-Marie Ampère
(1775-1836)**



**Carl Friedrich Gauss
(1777-1853)**



**Humphry Davy
(1778-1829)**



Ale
(



Georg Ohm
(1789-1854)



Michael Faraday (1791-1867)



**André-Marie Ampère
(1775-1836)**



**Humphry Davy
(1778-1829)**



Alessandro Volta
(1745-1827)



Georg Ohm
(1789-1854)



Carl Friedrich Gauss
(1777-1853)



André-Marie Ampère
(1775-1836)



Humphry Davy
(1778-1829)



Alessandro Volta
(1745-1827)



Georg Ohm
(1789-1854)



André-Marie Ampère
(1775-1836)



Humphry Davy
(1778-1829)



Alessandro Volta
(1745-1827)



Michael Faraday (1791-1867)



Humphry Davy
(1778-1829)



Georg Ohm
(1789-1854)



Carl Friedrich Gauss
(1777-1853)



Great Race Won by

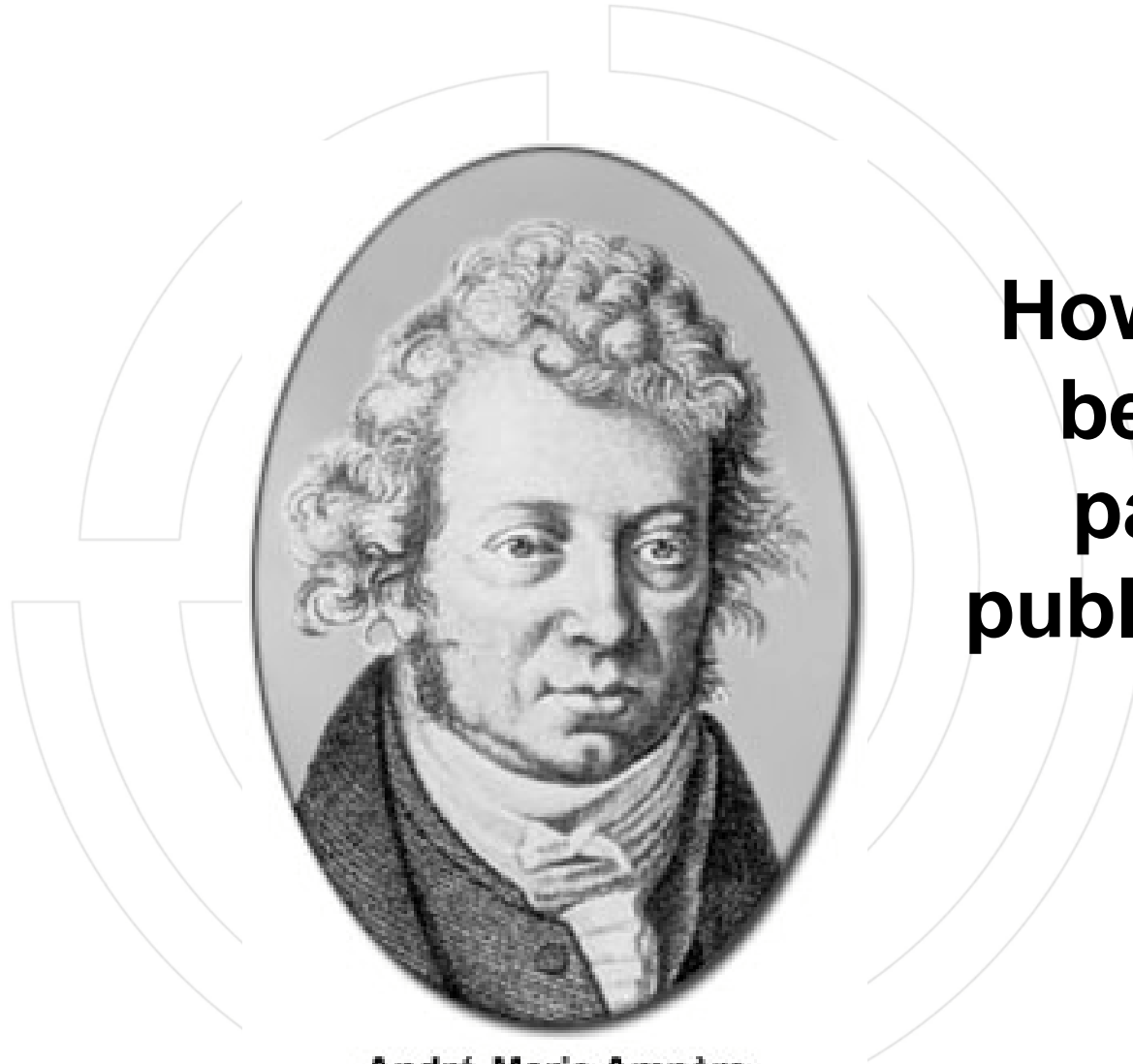

**How long
before
paper
published?**

**André-Marie Ampère
(1775-1836)**



André-Marie Ampère
(1775-1836)

**Wrote a Paper within ONE WEEK of
Orsted's Discovery**



André-Marie Ampère
(1775-1836)

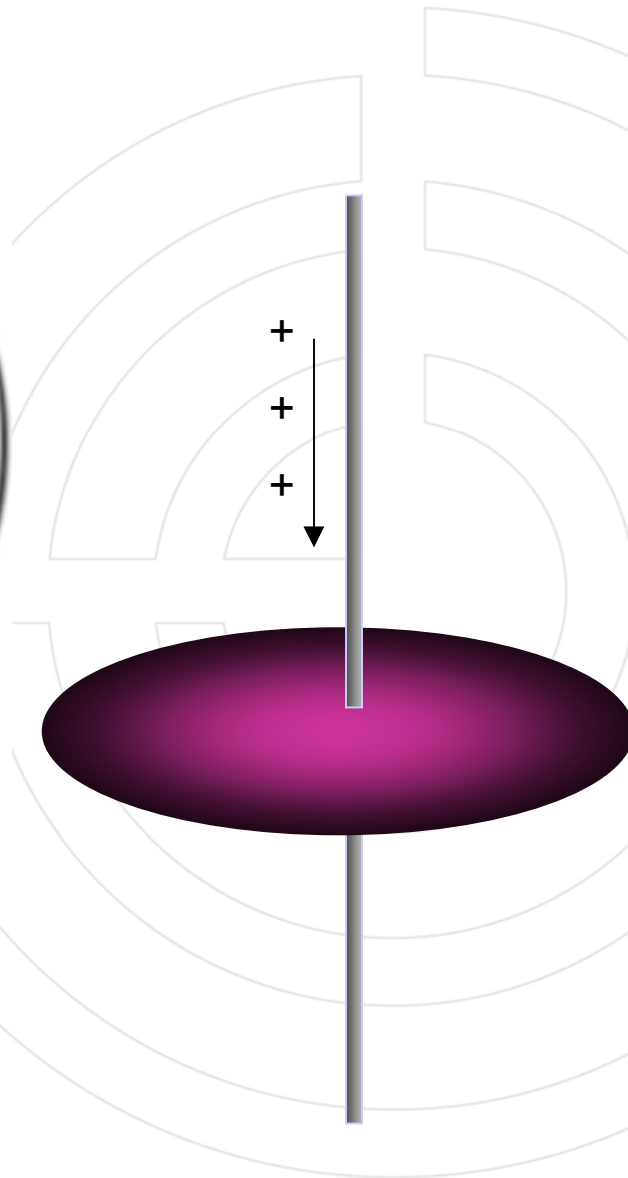

- The electric fluid flowing in the wire produces a circular magnetic effect
- The greater the fluid flow the greater the magnetic effect
- The magnetic effect is strongest close to the wire and falls with distance
- The magnetic effect is constant along a circumference (same distance from wire)
- The magnetic effect is time invariable (static)



André-Marie Ampère
(1775-1836)

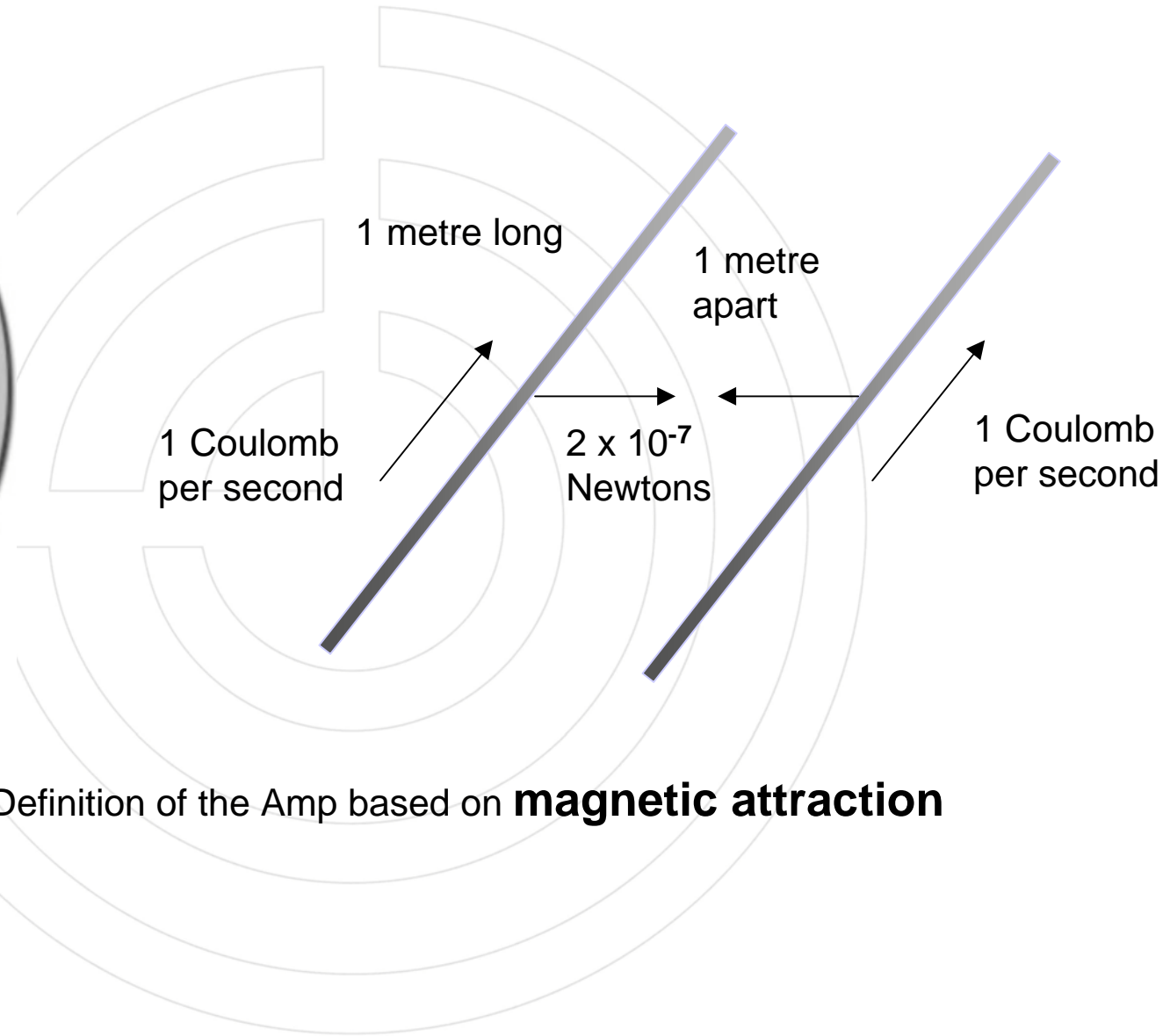

Definition of the Amp based on **magnetic attraction**

METRIC SYSTEM



André-Marie Ampère
(1775-1836)

FRENCH

Definitio



1769-1821

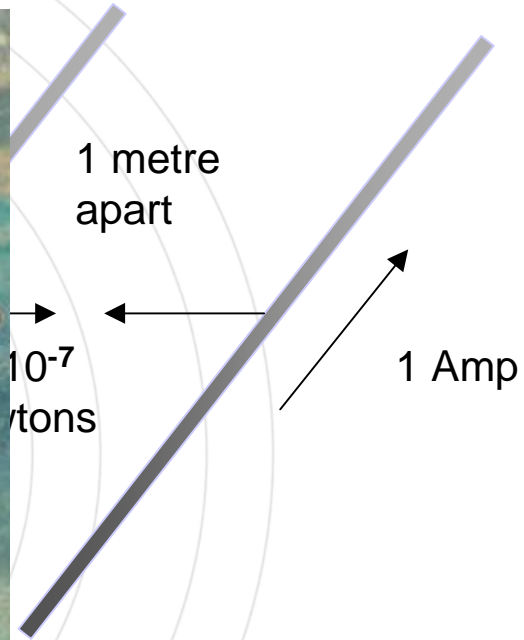

etic attraction



**A Relationship between Electricity
and Magnetism was Established
and Formulated**



Race Still On



Gauss's Law for Electric Fields

Gauss's Law for Magnetic Fields



The Next Breakthrough.....



The Concept of the FIELD

Einstein wrote of the Field Concept:

The most important invention since
Newton's time

All observations were
due to the presence of
the charged body

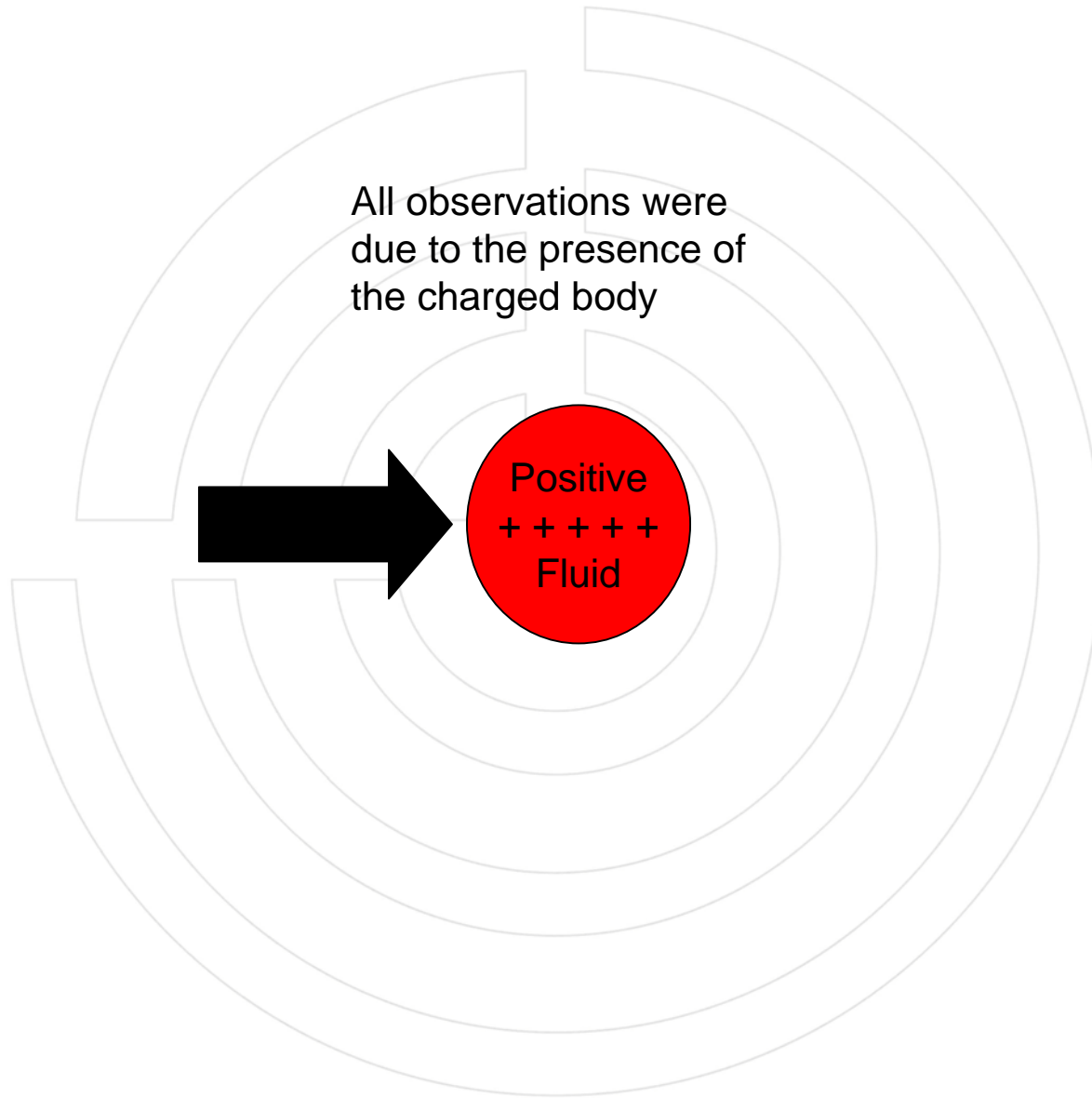



Magnetic field lines were introduced by Michael Faraday who named them "lines of force."



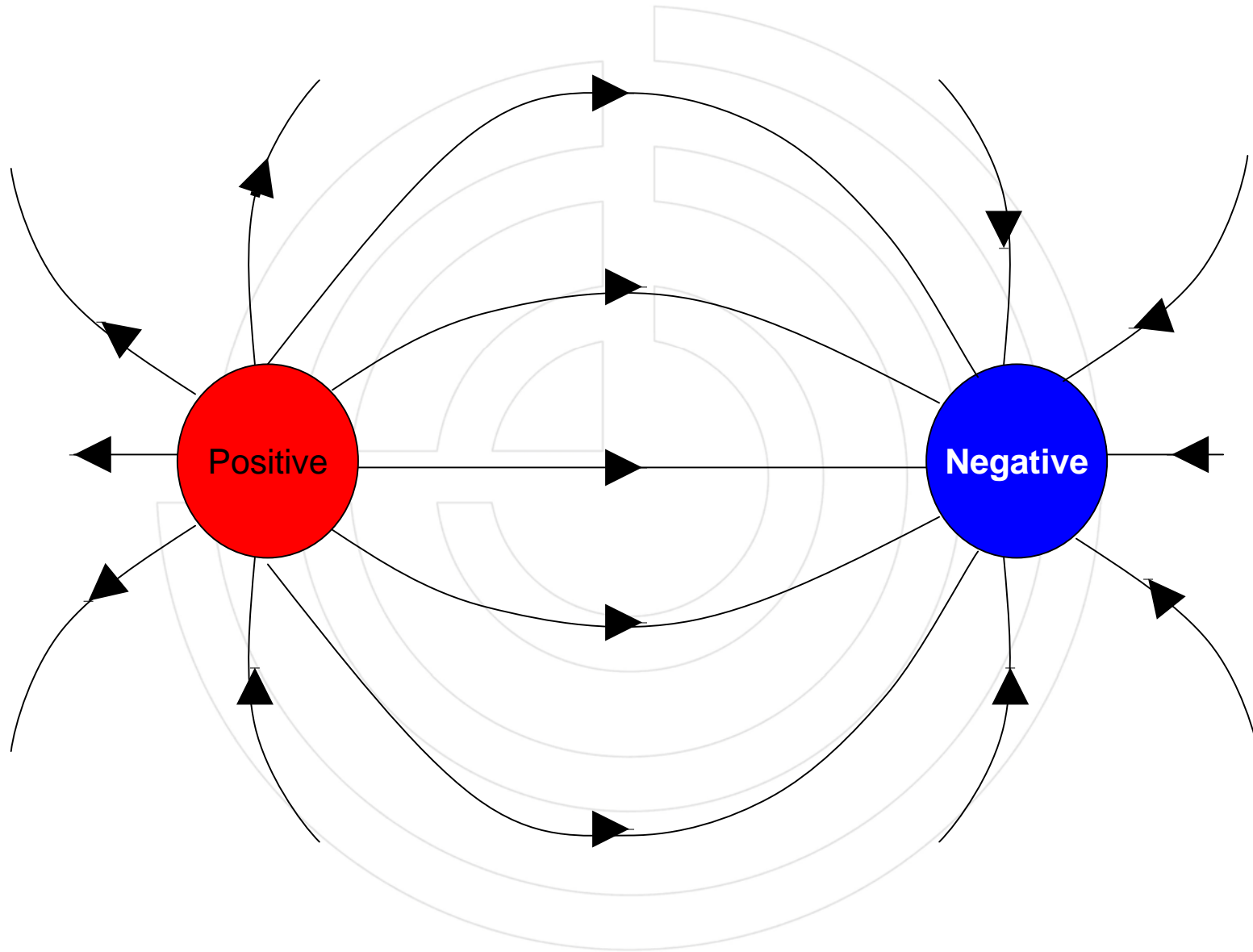

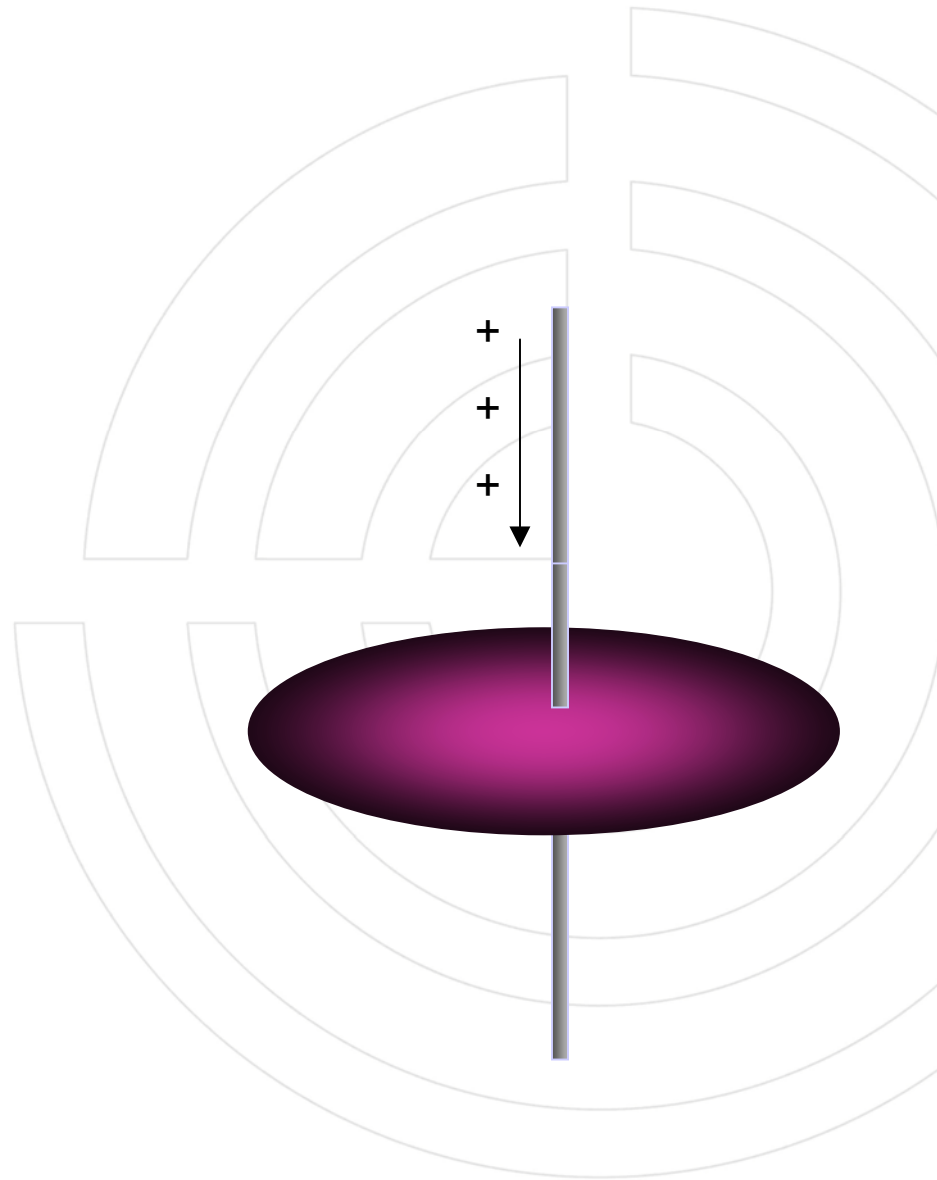



**If Moving
Fluid can
Create
Magnetism,
Can Moving
Magnetism
Create
Fluid?**

**Not Immediately Obvious a Dual
Existed**

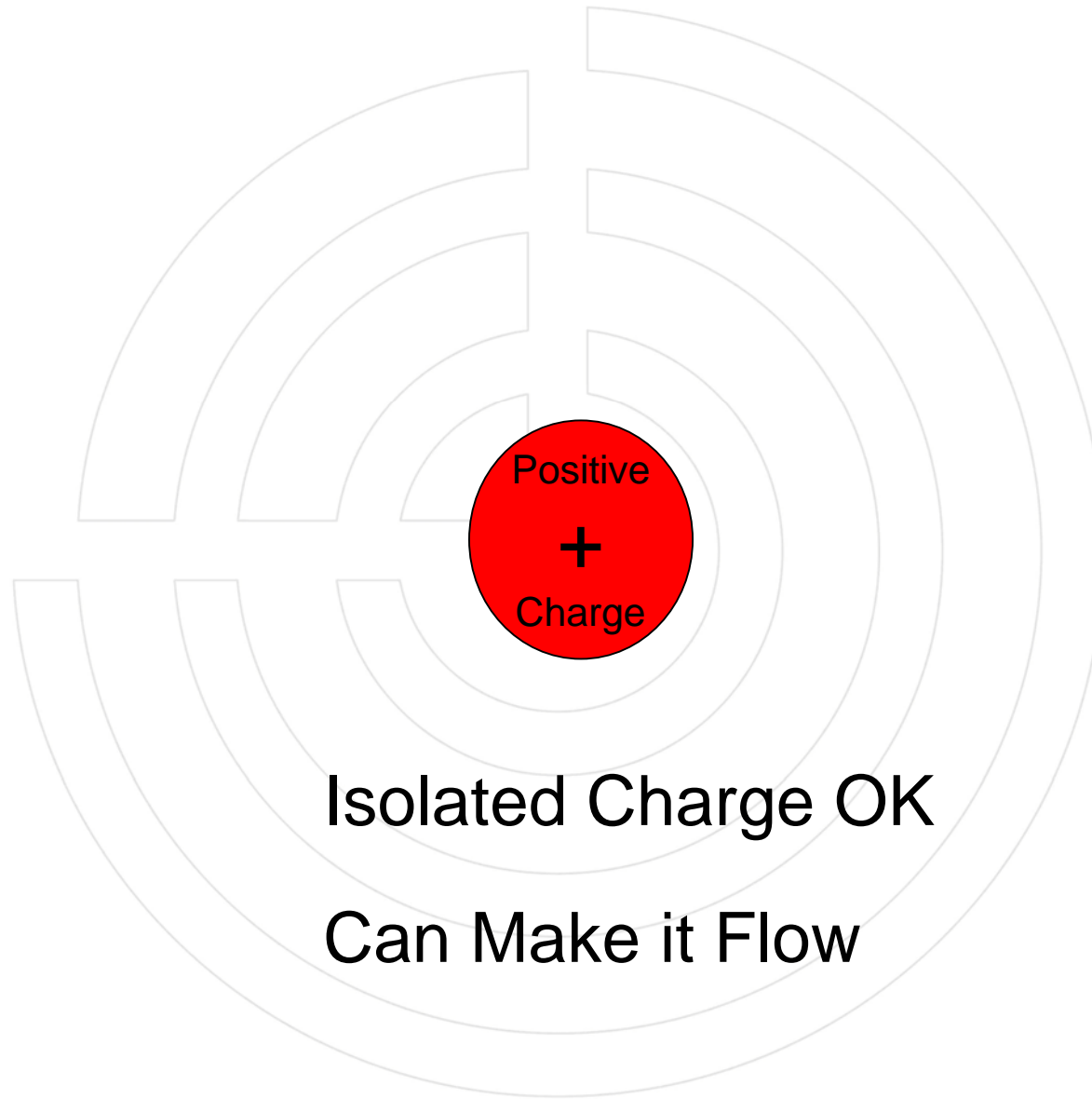
**Positive and Negative Charges can
Exist Alone - But a Magnetic Pole
Cannot**

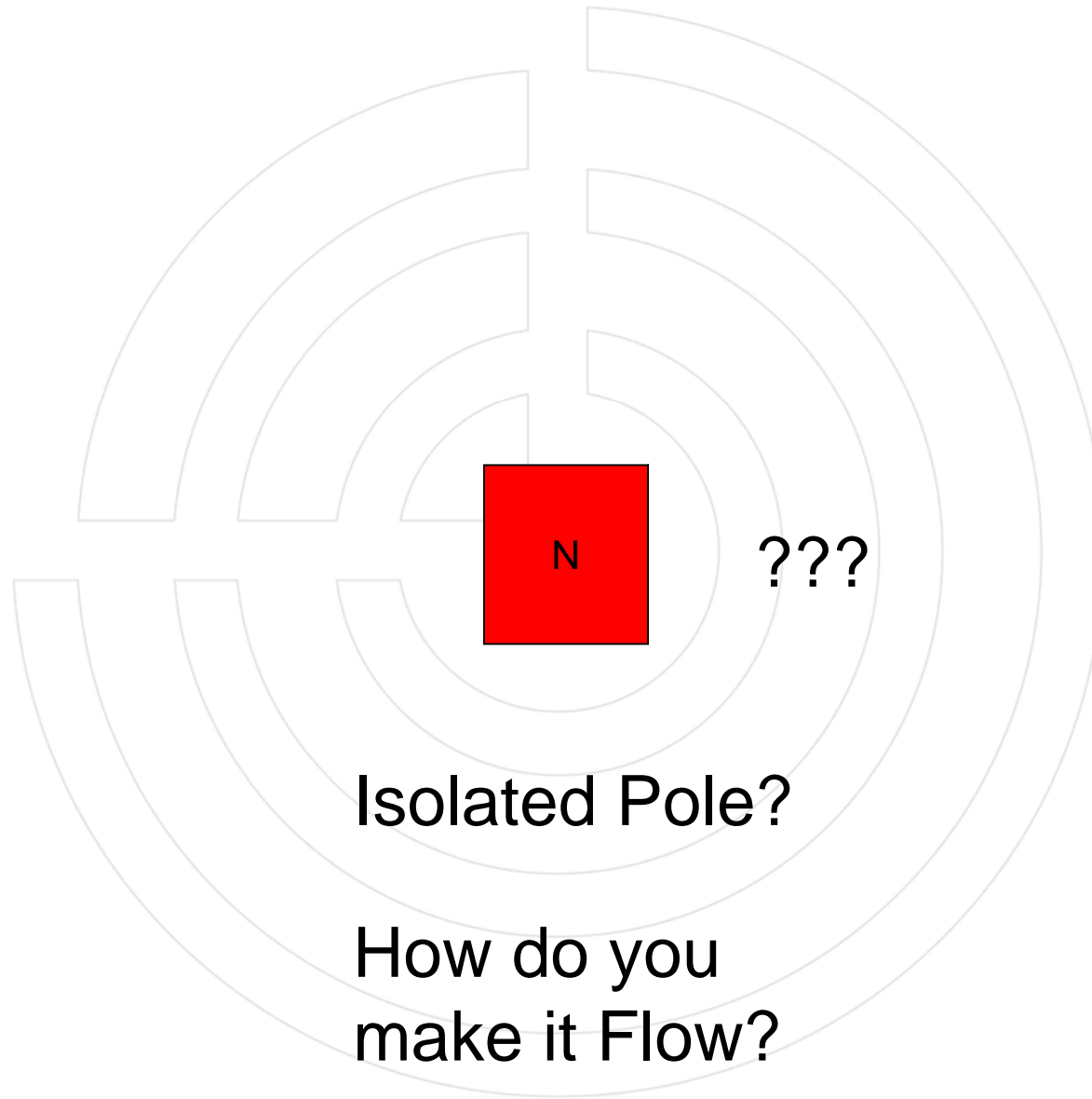





THEN..... IN 1831.....



Faraday discovered that moving a magnet in a coil of wire produced a flow of fluid

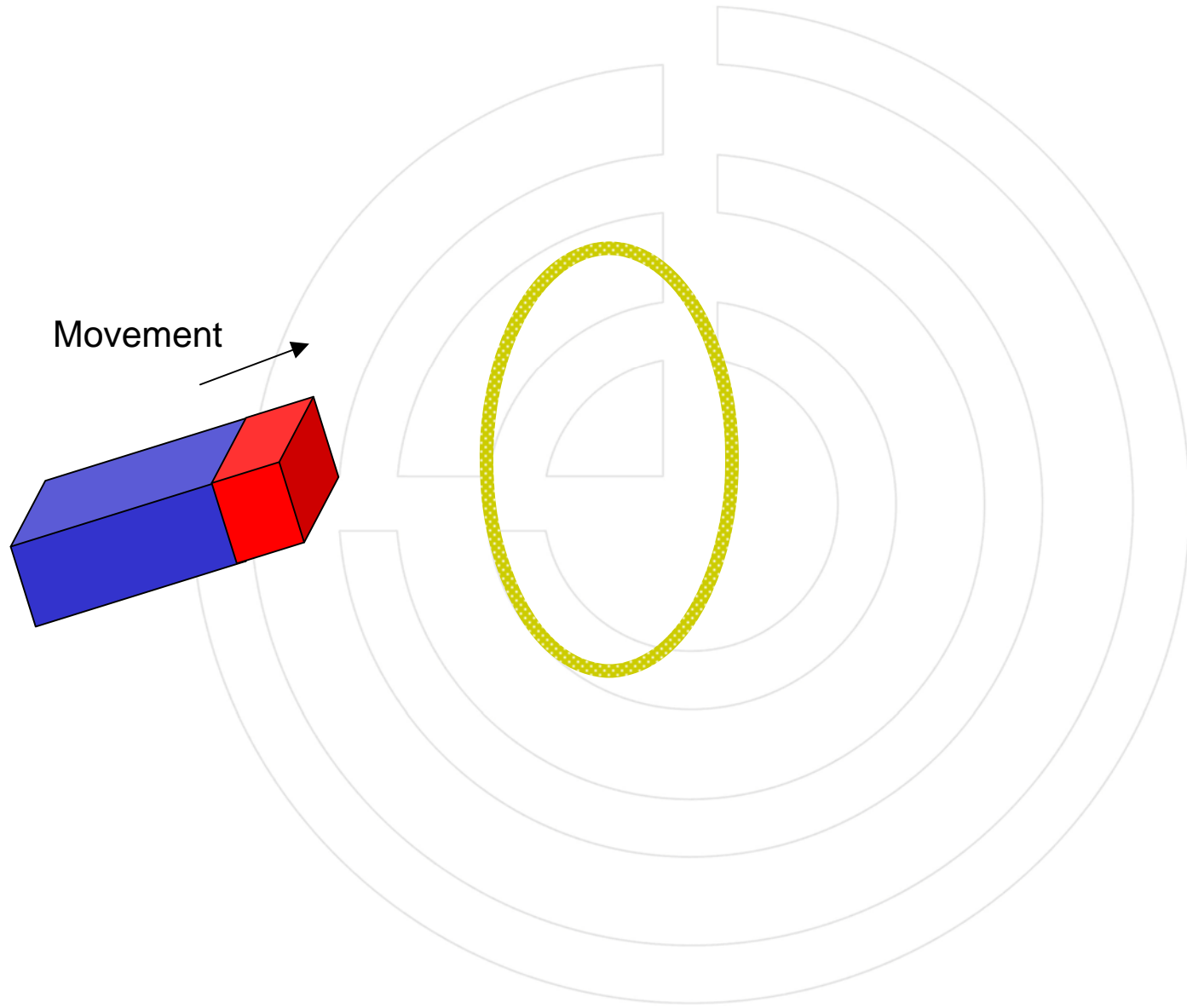

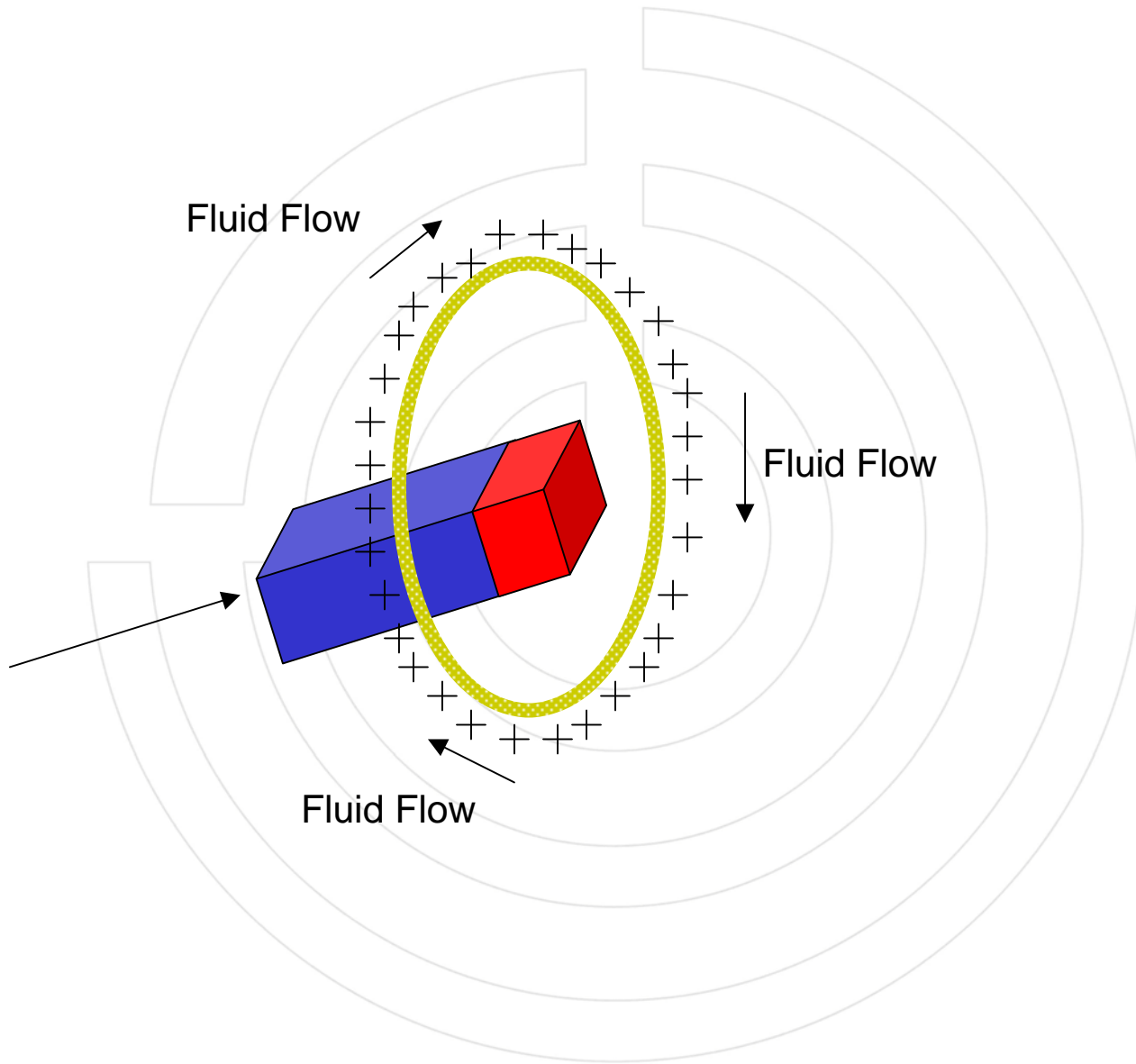



Race Still On



**In 1833 Gauss and Weber
Constructed the First
ElectroMagnetic Telegraph**

Enter James Clerk Maxwell



Library of Congress

1831- 1879

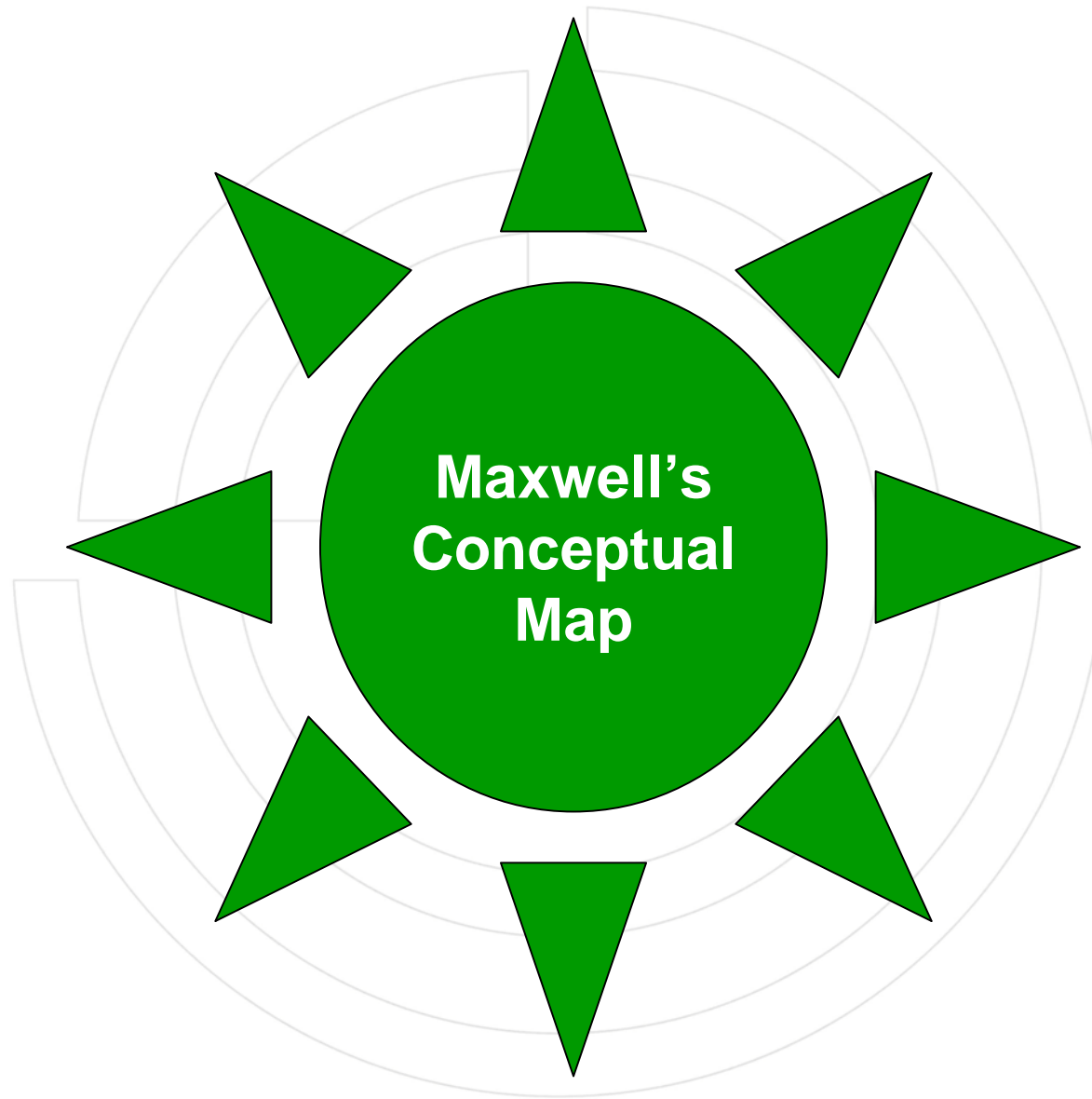

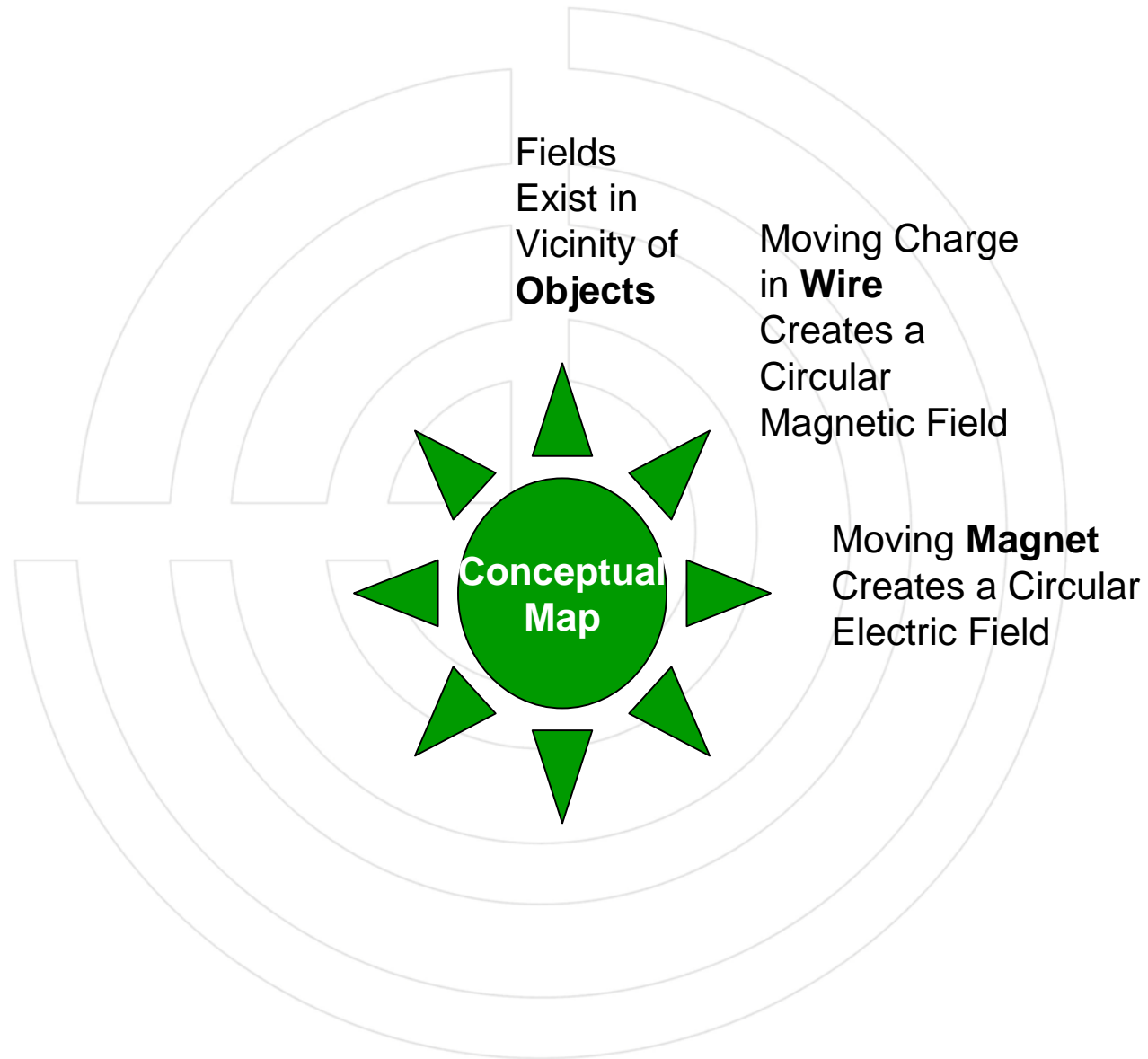

**Always
an
Anomaly**

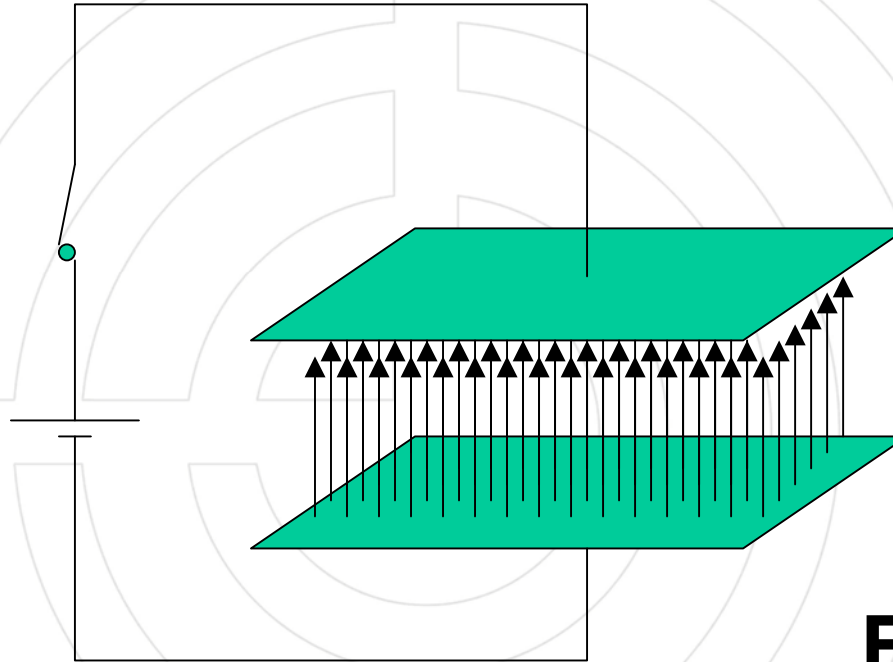

**No Current in Dielectric So
Magnetic Field Created by
Changing Electric Field**

**Extra Term
Added to
Ampere's
Law**

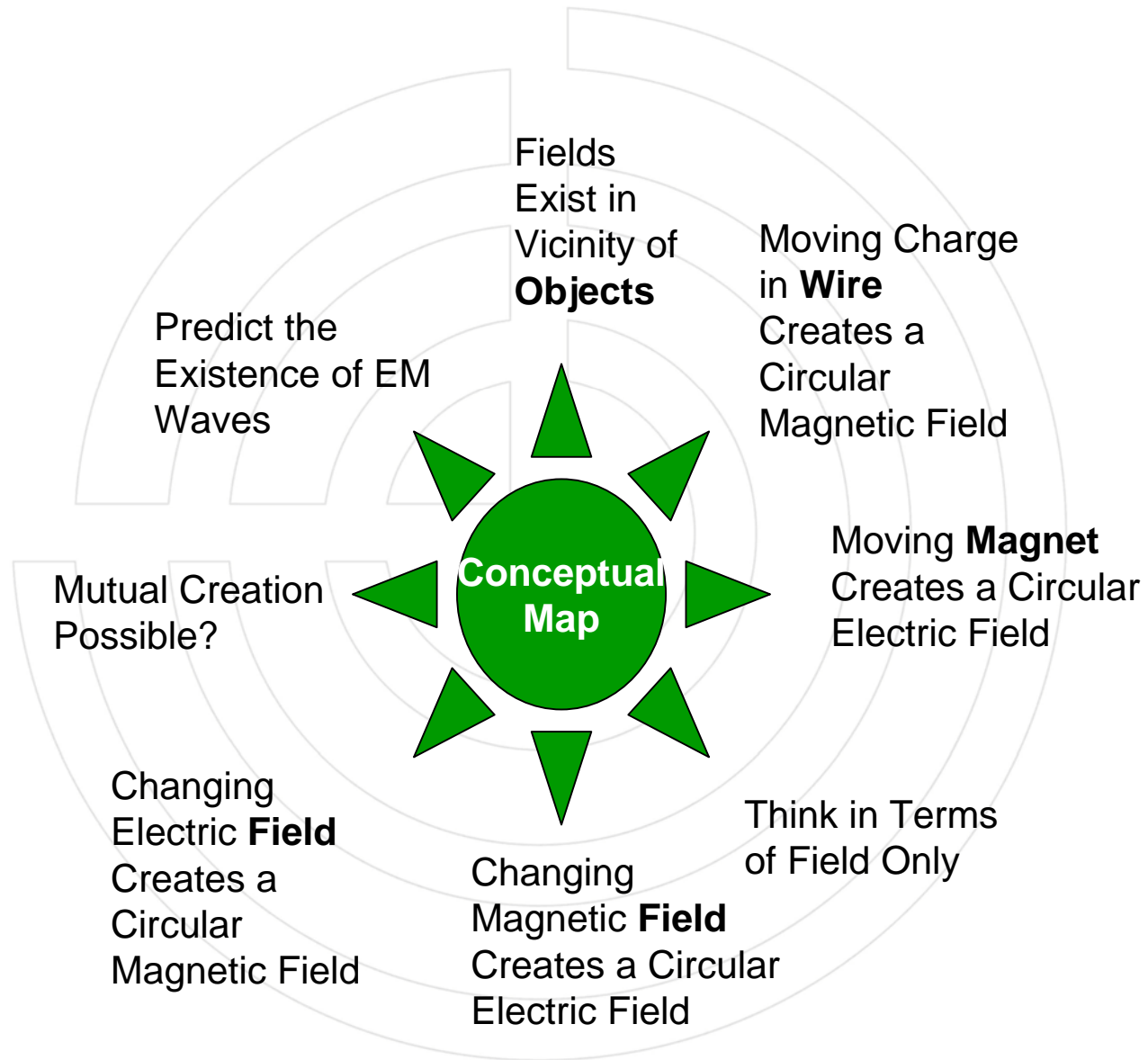



**In 1862, Using the Existing Four
Known Laws (with Additional Term
Added To Ampere's)**



Maxwell Predicted ElectroMagnetic Waves

**And Amazingly Showed these
would Travel at the Speed of Light**



Key Concept



The Self Perpetuating EM Wave

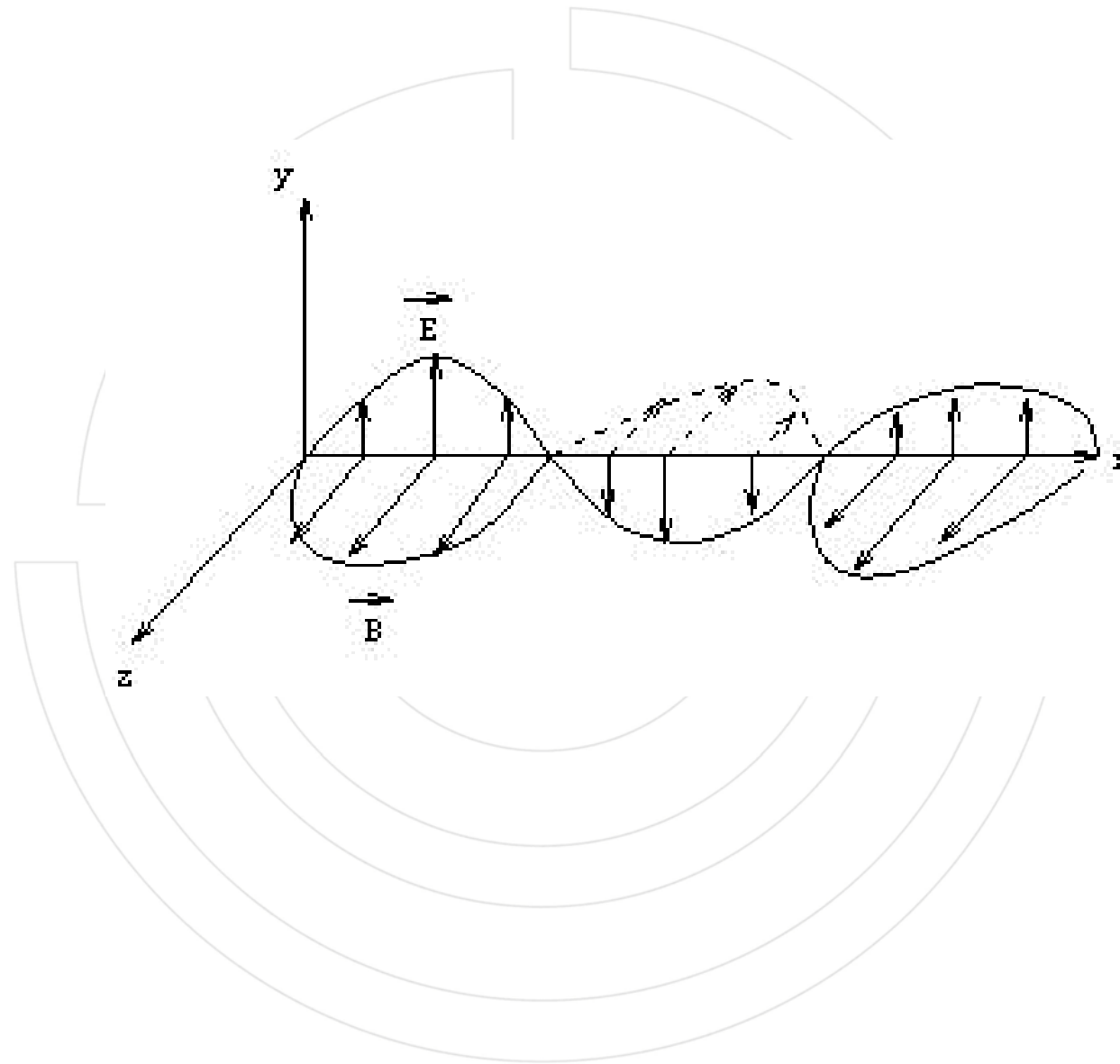

In 1886 **Heinrich Hertz** broadcast waves in his laboratory using an electric spark



1857-1894

Hertzian Waves

"Hertzian waves" investigated by
scientists all over the world



1857-1894



Guglielmo Marconi

1874-1937

1903 detected signals from Europe
as far as Cape Cod,
Massachussets

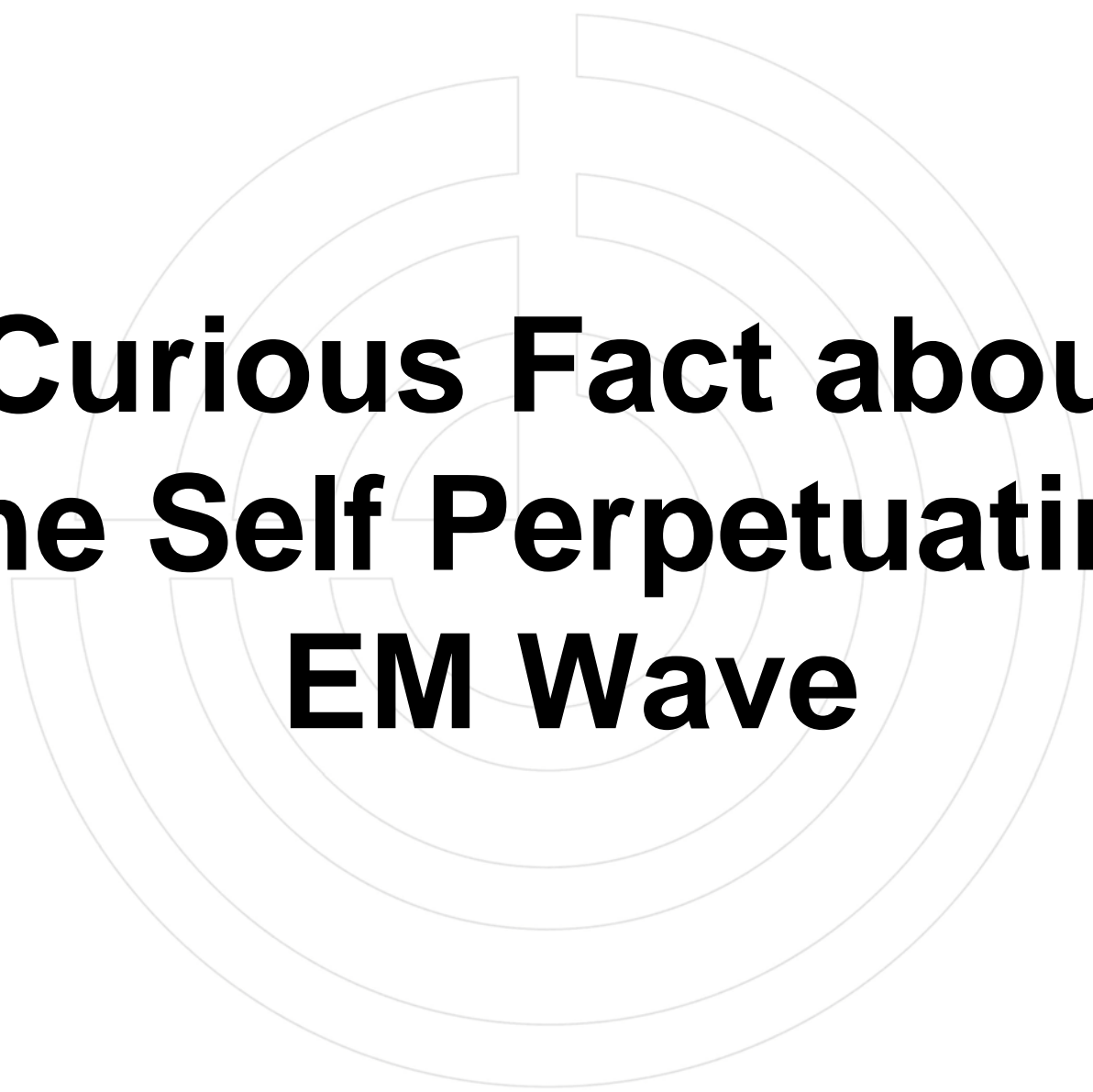

Curious Fact about the Self Perpetuating EM Wave

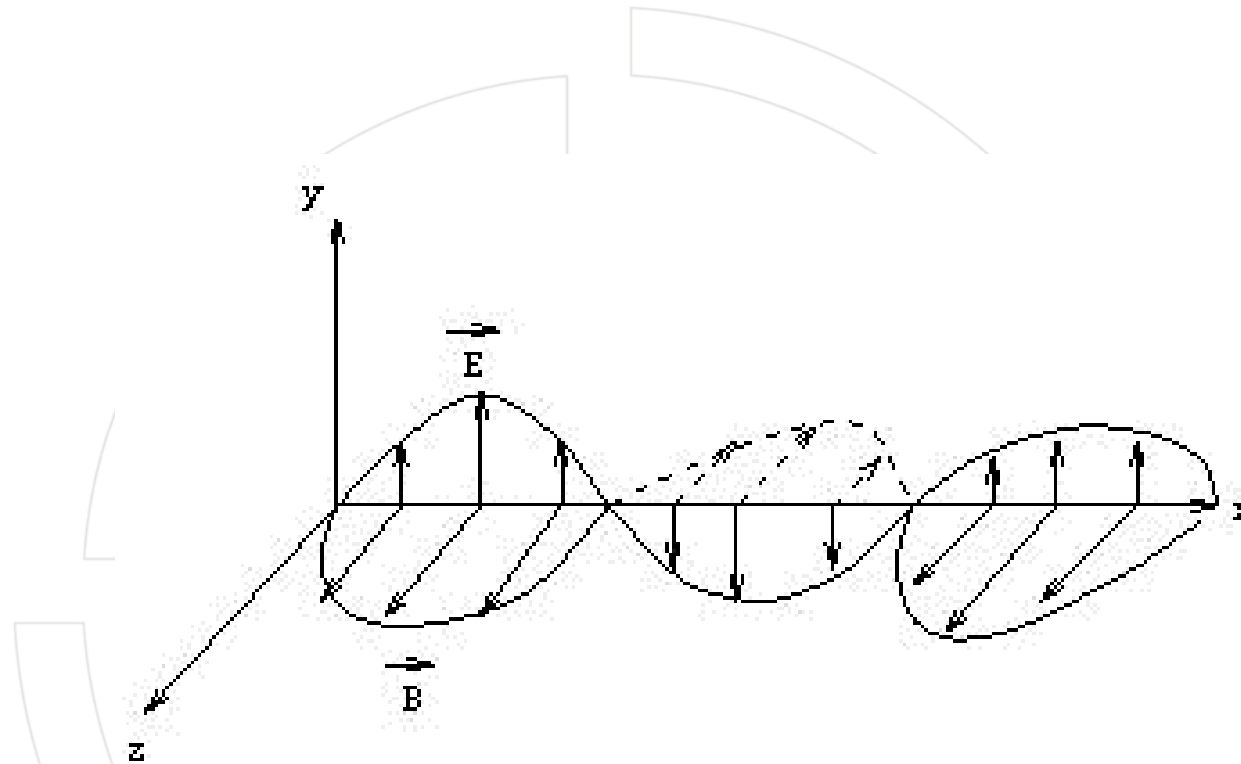

The Two Fields are In-Phase

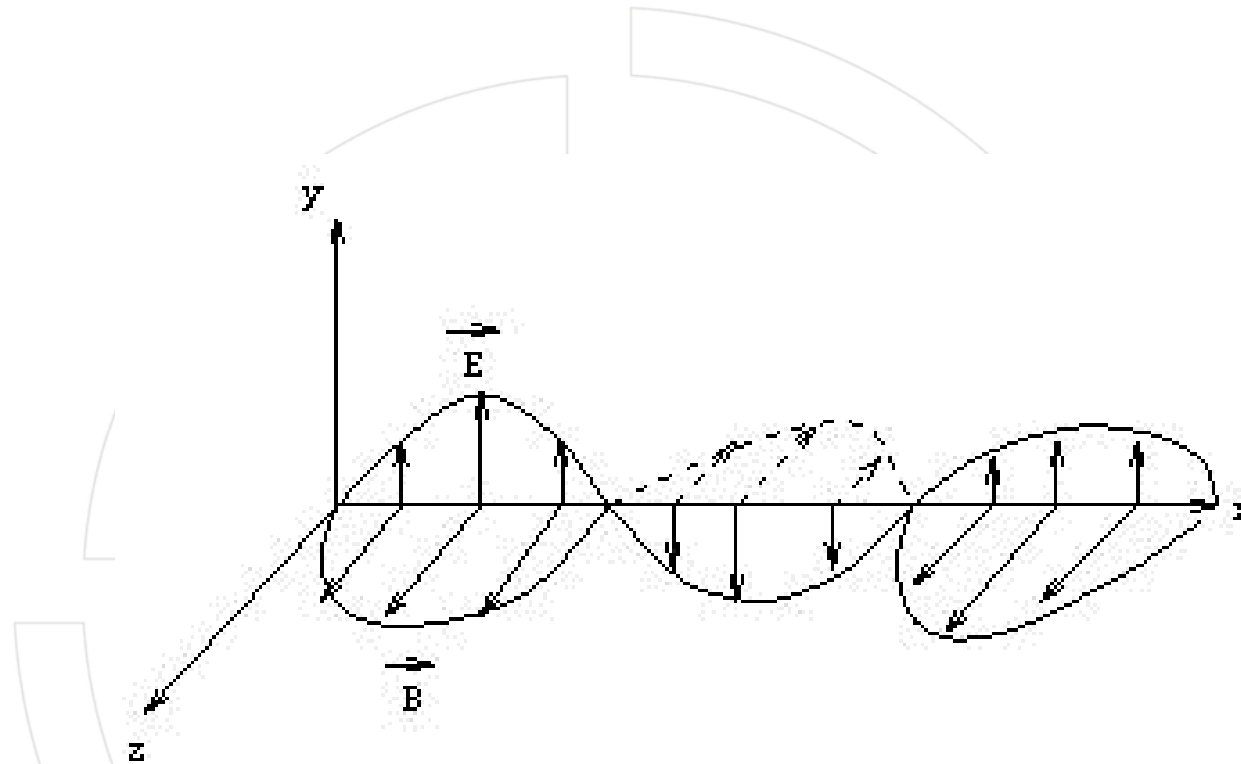

**Intuition Might Say Should be
Out-of Phase**



Curious Effect in a Transmission Line

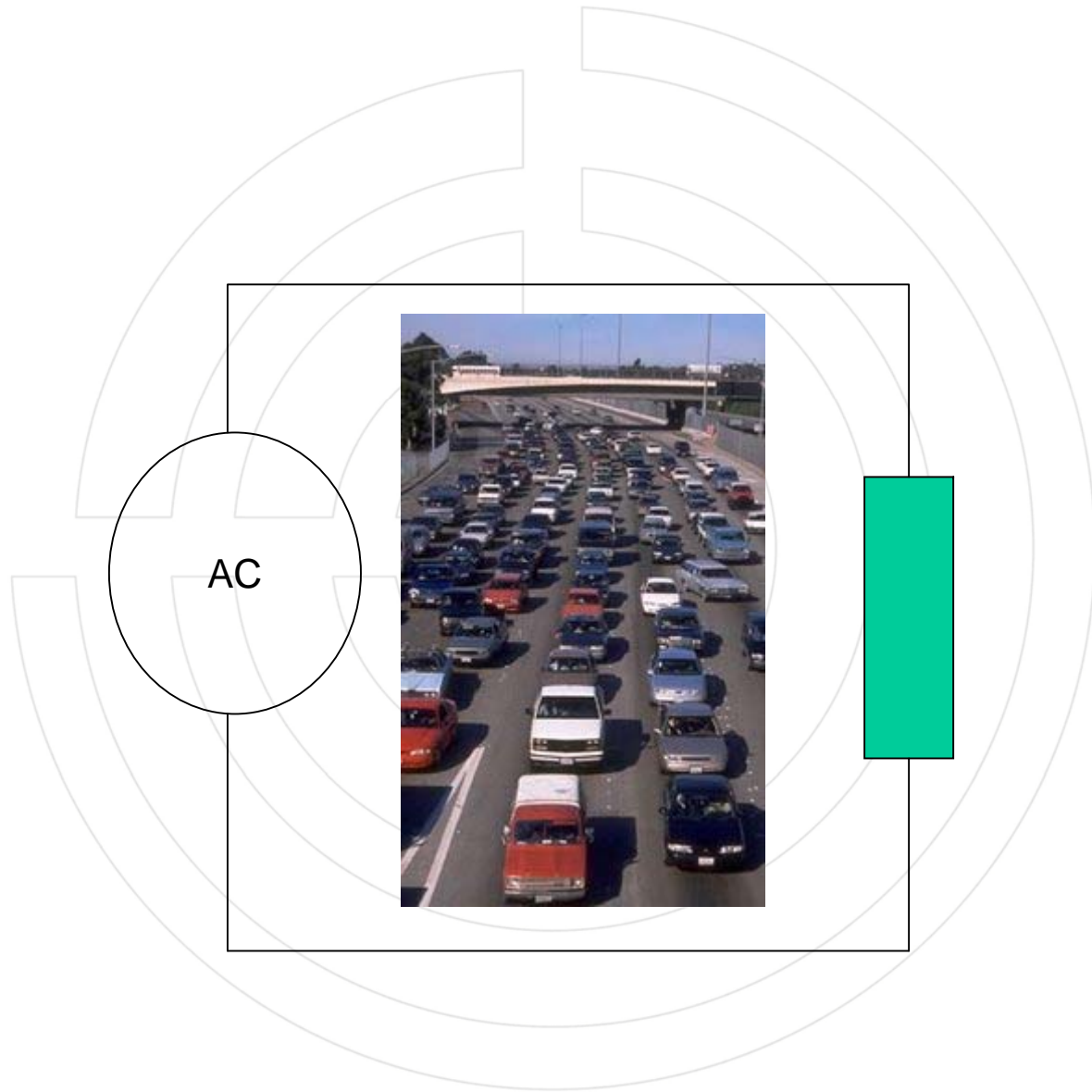



Transmission Line

RF





Transmission Line

RF





QUESTIONS?